

Kindergarten

From the *Just Turn & Share*® Centers Series

Kathryn Robinson

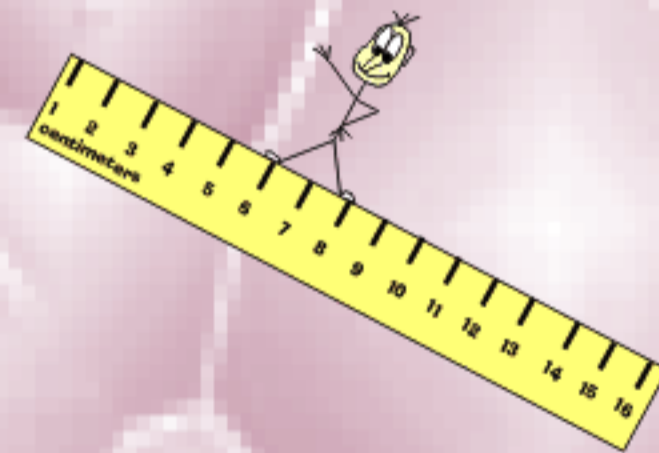
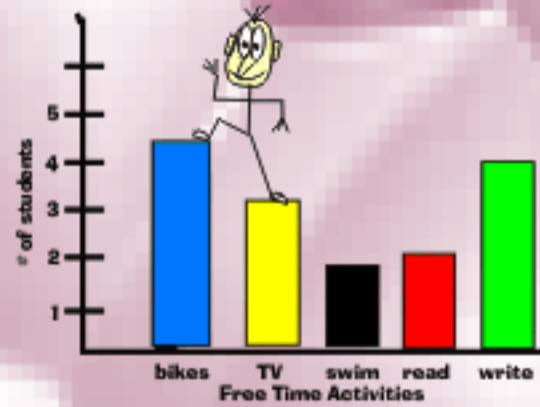
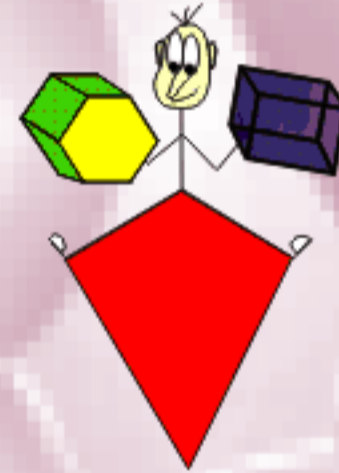
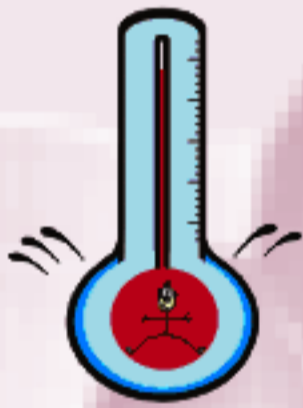
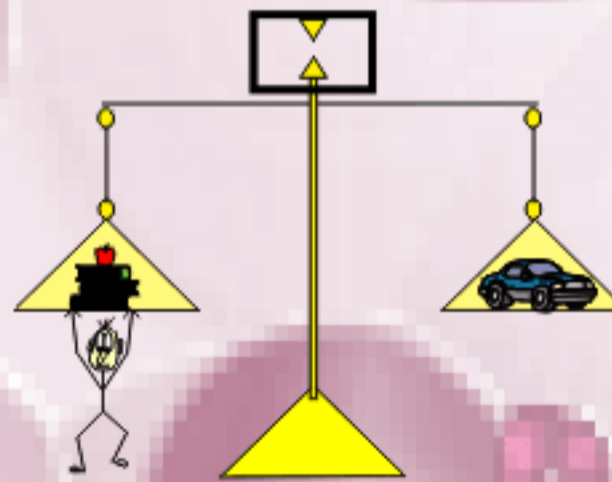
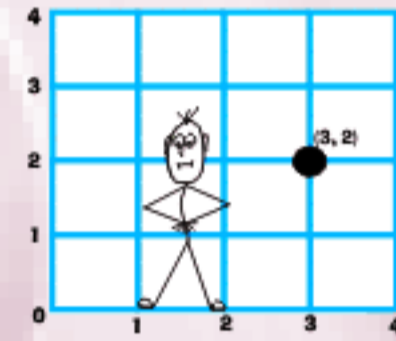

Real-World Mathematics

www.writemath.com



WriteMath Enterprises
2303 Marseille Ct. Suite 104
Valrico, Fl. 33594-7248
813 685 0392

weeks
1-10

Just Turn & Share[®]
Math Centers Series



Kindergarten

Weeks 1-10

Real-World
Mathematics
that
students
understand

Kathryn Robinson



WriteMath Enterprises, Inc.
Valrico, Florida

The student pages in this publication are designed to be used with appropriate duplicating equipment to reproduce copies for permission classroom use only. WriteMath Enterprises, Inc. grants to classroom teachers only to reproduce these student sheets for students in one class per year per book purchased by the school or the teacher him/herself.

Copyright © 2004 WriteMath Publications
All rights reserved – Printed in the U.S.A.
Published by WriteMath Enterprises, Inc.
2303 Marseille Ct., Valrico, FL 33594

- I dedicate this series to my husband, Steve Robinson, for advising, supporting, guiding, and editing years of work and making my dreams possible.
-
- I dedicate this series to Candace Chappell-George who gave me the support and pacing information that I needed as a co-worker and a friend.
-
- I would also like to dedicate this series to Karen Pletcher, Valerie Quackenbush, Rebecca Christopher, and Jennifer Driskell and the Kindergarten students at Wahneta Elementary School in Polk County who gave me suggestions and positive information that I needed to make this work for our favorite people in the world – STUDENTS!

This book is published by WriteMath Enterprises.

ISBN 1-931970-27-0

Graphics from: Corel Draw 10 (Corel Corporation) and Microsoft Publisher

Copyright laws prohibit the duplication of any materials in this publication under penalty of law.

Copyright © 2004 Kathryn Robinson

Introduction

Kindergarten is the initial grade level book in the K-5 'Just Turn & Share'® Mathematics Series. It is one of three books in the Kindergarten series: Week 1-10, Weeks 11-20; and Weeks 21-30. This series gives students **daily** practice in several math areas. After gradually working in a center-based atmosphere, students can tackle all of the centers in less than half an hour (this includes correcting). This program can be used in conjunction with any regular math series. Some students have difficulty attaining proficiency in specific math areas due to the limited practice provided by a textbook. 'Just Turn & Share'® math centers provide real-world practice with mathematical concepts.

The series is designed for center-based review of concepts or as whole-group overhead instruction. These lessons are designed to provide practice for 30 weeks of the school year. The program contains one-week's worth of practice in each concept. Each concept is covered for an entire week before a new concept is introduced to the students. During each week only the numbers change - not the concepts. The first day of each week should be set aside as a mini-lesson to preview the materials that the students will engage in independently over the course of the week. Ideally the teacher will conduct a SHORT mini-lesson on a daily basis before students begin work on the materials. These mini-lessons should be based on areas of difficulty that students are experiencing in the centers. Each week has material to be duplicated to create hands-on materials for the students with which students can practice the concepts. The hands-on aspect of the program is critical for students to be able to grasp abstract or difficult concepts.

During the first few weeks, I recommend working with the students as they work through the centers. This will help them understand the concepts that will be covered in the centers at a later time. Being free to rotate among the students will help them quickly grasp the mathematical concepts

Centers

Just what role do centers play in an educational setting? Centers are an area of learning in which students can work together cooperatively, utilize hands-on materials, and practice educational concepts without fear of failure.

Behavior Management

Controlling behavior is the most important aspect of using centers in the classroom. There are a few simple rules in our centers:

- Respect others
- Help others learn
- Leave the center clean for others

My goal in a center-based classroom is to improve learning, maintain a highly-focused learning environment, and allow students to progress at their own pace. I think that the most important step to a well-structure classroom environment for centers is to spend the first two weeks spending time learning, expect students to behave appropriately, allow them to have an opportunity to seek assistance, maintain a high-level of on-task behavior, and assess their learning to determine educational gains. Therefore, the first two weeks are critical to the success of a center-based environment. The following assistance-support ideas have proved successful to me over the last 17 years.

Arrangement

I place the centers strategically around the exterior of the classroom. Students need enough room to not be bumping into one another and complete their work successfully. Space is another priority in considering behavior management issues. When students are crowded together and knocking one another, behavior becomes disruptive. I do not want the rotation to be confusing and allow students to waste time between rotations. Centers are arranged in a clockwise rotation around the room.

Each center should have as much hands-on materials as possible that relate to the information to promote understanding. Students need to manipulate materials with their hands to grasp many mathematical concepts. For example, a large clock should be at the time center, a variety of shapes should be at the geometry center, counters should be at any center that requires addition or subtraction, Unifix cubes should be at the algebra or measurement centers, etc. Manipulation leads to understanding.

Beginning Centers

A. Best Scenario:

1. It is very important to discuss how ‘we help one another’. We talk about how it is NOT really helping another student to “give” them the answer. A good friend would ‘show them how to do the problem.’ Center work is a great time for student interaction in an on-task situation and for peer-demonstration, which reinforces learning.
2. As they are working, I move around the classroom assisting students as needed. It is important not to be doing ‘other necessities’ like checking their work, catching up on paper work, etc during this time. This is a time to provide support and determine areas of difficulty. Once centers are up and running (after a few weeks), you may want to use this time to provide short math mini-lessons, based on the centers, with a couple of students at a time.

Setting Up

Always reserve Mondays to review the concepts coming up in the next week’s worth of centers. This is the first week that students will move through centers rather than work at their seats. To set the centers up with the least amount of effort, I recommend placing a week’s worth of the work in each of eight sheet protectors. For example, place Day #1 in a single sheet protector with Day 2 A & B right behind with Day 3 and 4 directly behind them in the same sheet protector.

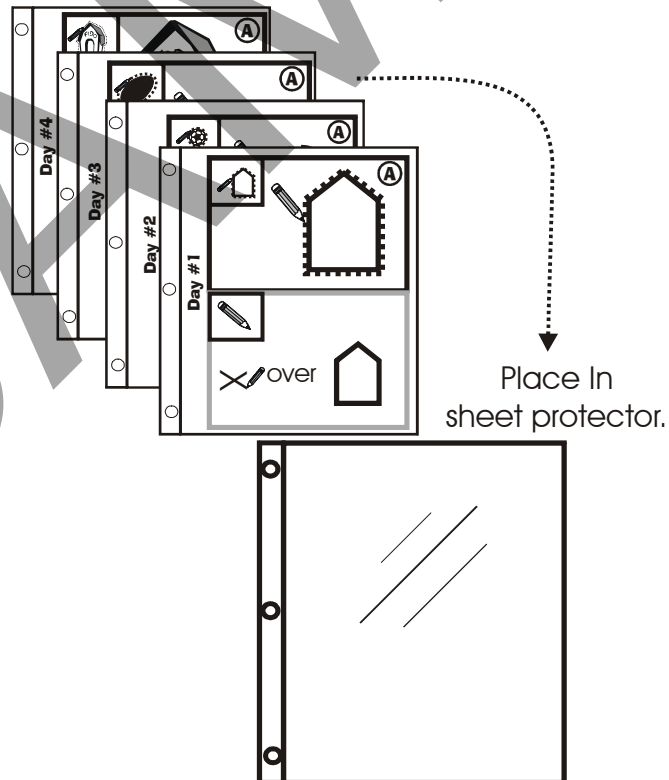

The sheets are placed at each center area for the whole week.

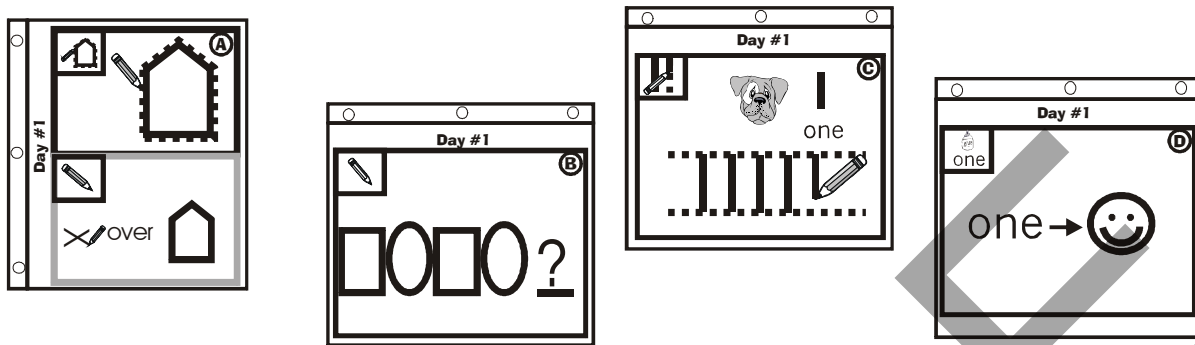

At the end of the day, a student can pull out the front center (**Day #1**) and place it at the back of the pages in the sheet protector.

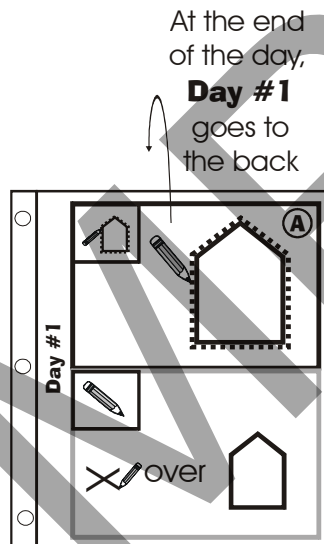

If you have any questions please feel free to e-mail us on our website:

www.writemath.com

I know that you will have as much fun employing this program as I have had designing it. Remember the program is as simple as *turning each page and sharing* the activities with your class.

So go ahead...

Just Turn & Share®

our math with your students.

Contents

Introduction	III
How to Set Up Centers Information	V
Contents	VII
<i>Week 1:</i>	1
<ul style="list-style-type: none">• Trace one object• Draw one step in a pattern• Write the numeral '1'• Draw, cut out, trace, and color one object	
Templates for Week 1	23
Direction Cards	24
Over & Under Information Sheet	26
Numbers Chart	29
Numbers Line for Math Centers	32
Answers for the Week	33
Answer Sheet	34
<i>Week 2:</i>	1
<ul style="list-style-type: none">• Trace one object• Draw one step in a pattern• Write the numeral '1'• Draw, cut out, trace, and color one object	

Templates for Week 2.....	21
Answers for the Week	27
Answer Sheet	28
<i>Week 3:</i>	1
<ul style="list-style-type: none">• Work on the terms <i>over & under</i>• Draw the next step in a pattern• Draw open & closed figures• Draw, cut out, trace, and color two objects	
Templates for Week 3.....	20
Answers for the Week	27
Answer Sheet	28
<i>Week 4:</i>	1
<ul style="list-style-type: none">• Work on the terms <i>inside & outside</i>• Draw the next step in a pattern• Draw <i>open & closed</i> figures• Draw, cut out, trace, and color two objects	
Templates for Week 4.....	20
Inside & Outside Information Sheet	22
Direction Card	29
Answers for the Week	30
Answer Sheet	31

Week 5: 1

- Telling time to the hour
- Draw the next step in a pattern
- Addition
- Money: penny (front of coin)

Templates for Week 5.....20

Answers for the Week25

Answer Sheet26

Week 6: 1

- Telling time to the hour
- Draw the next step in a pattern
- Addition
- Money: penny (*back of coin*)

Templates for Week 6.....20

Answers for the Week25

Answer Sheet26

Week 7: 1

- Telling time to the hour
- Draw the next step in a pattern
- Addition
- Money: penny (*back of coin*)

Templates for Week 7.....20

Answers for the Week26

Answer Sheet27

Week 8: 1

- Telling time to the hour
- Draw the missing step in a pattern
- Addition & fact families
- Money: penny (front & back of coin)

Templates for Week 8.....20

Answers for the Week25

Answer Sheet26

Week 9: 1

- Telling time to the hour
- Draw the missing step in a pattern
- Addition & fact families
- Money: penny (front and back of coin)

Templates for Week 9.....20

Answers for the Week26

Answer Sheet27

Week 10: 1

- Telling time to the hour
- Draw the missing step in a pattern
- Addition & fact families
- Money: nickel (*front and back of coin*)
- Measurement with Unifix cubes

Templates for Week 10.....24

Answers for the Week27

Answer Sheet.....28

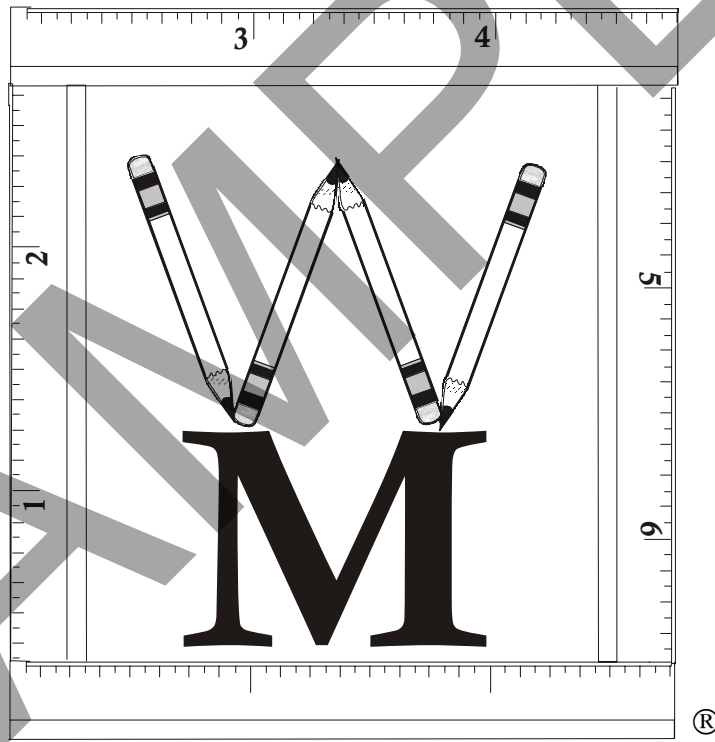

WriteMath Enterprises
www.writemath.com

Centers in the 'Just Turn & Share' Math Center Series:

- Kindergarten: Weeks 1-10
- Kindergarten: Weeks 11-20
- Kindergarten: Weeks 21-30

- Grade One: Weeks 1-10
- Grade One: Weeks 11-20
- Grade One: Weeks 20-30

- Grade Two: Weeks 1-10
- Grade Two: Weeks 11-20
- Grade Two: Weeks 20-30

- Grades 3-5:
 1. Algebra
 2. Calendar
 3. Estimation
 4. Fractions & Decimals
 5. Geometry
 6. Graph
 7. Grid
 8. Linear Measure
 9. Money
 10. Number Sense
 11. Place Value
 12. Temperature
 13. Thinking: Range, Median, Mode, Mean
 14. Time
 15. Volume
 16. Weight & Mass

For more information:

WriteMath Enterprises
2303 Marseille Ct. Suite 104
Valrico, FL. 33594
(813) 685 – 0392
website: www.writemath.com



Just Turn & Share

Kindergarten

Weeks 1-10

by

Kathryn Robinson

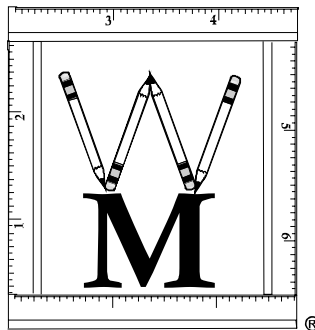

WriteMath Enterprises, Inc.
www.writemath.com

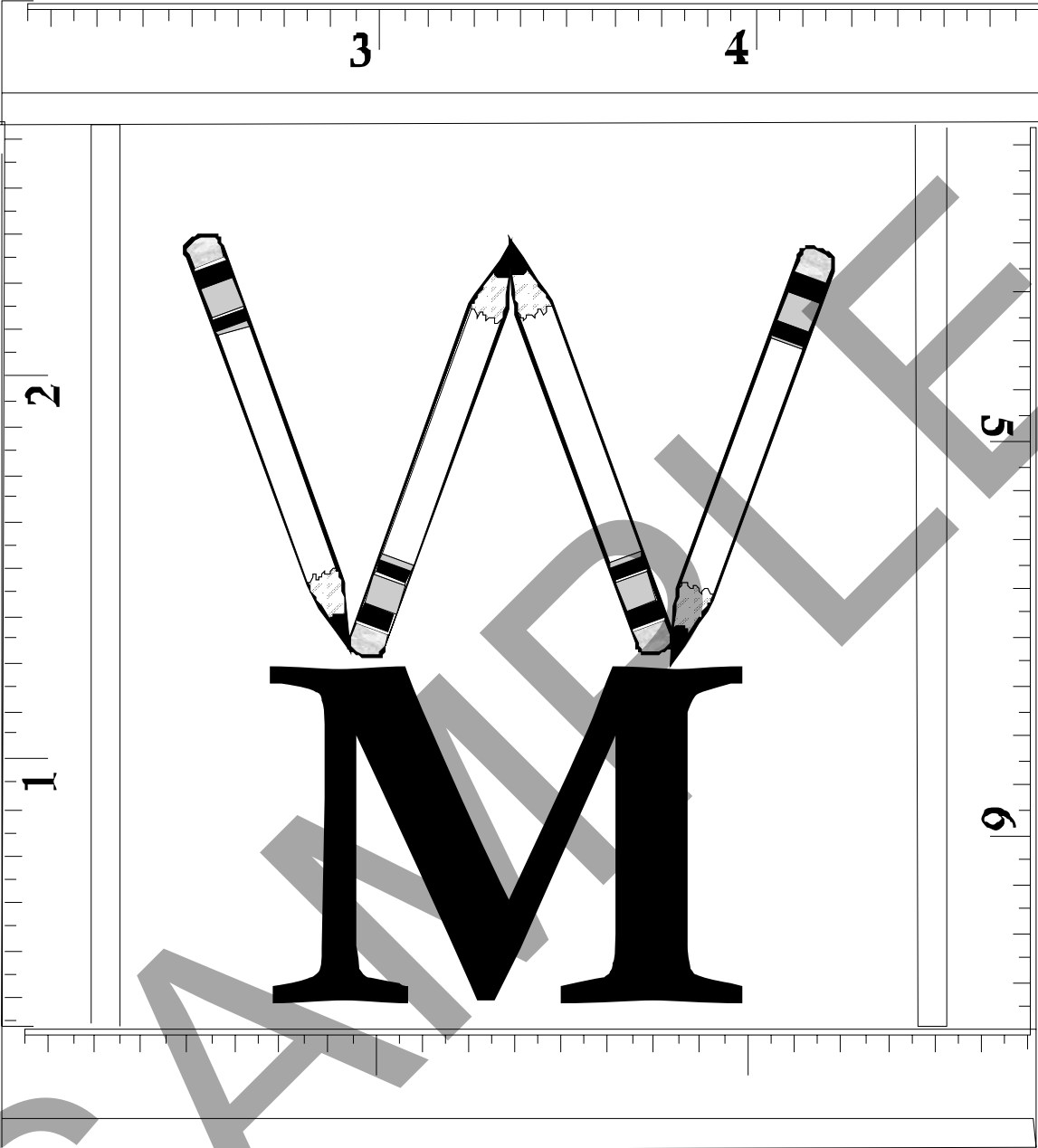

www.writemath.com

Week 1

Days #1 - 4:

Synopsis: During this first week of centers, students will be working with the number 'one' in a variety of ways. They will:

- Trace one object
- Draw one step in a pattern
- Write the numeral '1'
- Draw, cut out, trace, and color one object

Supplies:

- Answer Sheet (*template after Answers for the Week*) or half-sheets of 8 1/2" x 11" paper
- Pencils, crayons, and glue
- Copy of Directions Cards for all problems (*template after Daily Activities*)
- Copy of *Over & Under* Information for "A" (*template after Daily Activities*)
- Patterns for pentagon/house, soccer ball, football, baseball for "A" (*template after Daily Activities*)
- Practice stencils for each student for "A" (*template after Daily Activities*)
- X's & house shape for each student for "A" (*template after Daily Activities*)
- Patterns for rectangle & oval for "B" (*template after Daily Activities*)
- Number tracing sheet for "C" - optional (*template after Daily Activities*)
- Stencil of 'Happy Face' cut out for "D" (*template after Daily Activities*)
Day #1 will need a small copy of the happy face cut out for each student. (*template after Daily Activities*)
- Copy of *Numbers Information* Sheets for "D" (*template after Daily Activities*)

Directions:

1. Use Answer Sheet (*template after Answers for the Week*) or students fold 8 1/2" paper in half. On the front they write a small 'A' in the top half of the front side of the paper, 'B' in the bottom half of the front side of the paper, 'C' in the top half of back side of the paper, and 'D' in the bottom half of back side of the paper.

1. Fold paper.



2. Open paper.

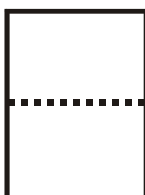





3. Write A & B on the front.

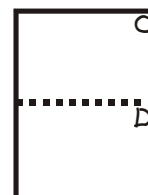

4. Write C & D On the back.



2. Before beginning Week 1’s work, discuss the following symbols with student:

-  means “Draw”.
-  means “Outline”.
-  means “Glue”.
-  **one** means “Color the number of objects indicated” (*A specific color word is sometimes indicated on the crayon.*)
- A green box means “Do this task first”.
- A red box means “Do this task last”.

3. During the first week or two, you may want to do the tasks with the students.

4. Before beginning Activity ‘**A**’ with students, outline the top box of problem “**A**” on Days #1 – 4 with a green marker or crayon.

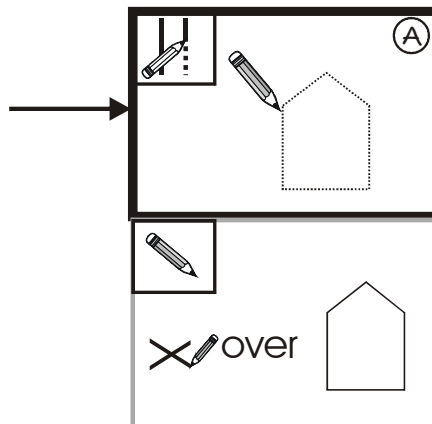

5. Next, outline the bottom box of problem “A” on Days #1 – 4 with a red marker or crayon.

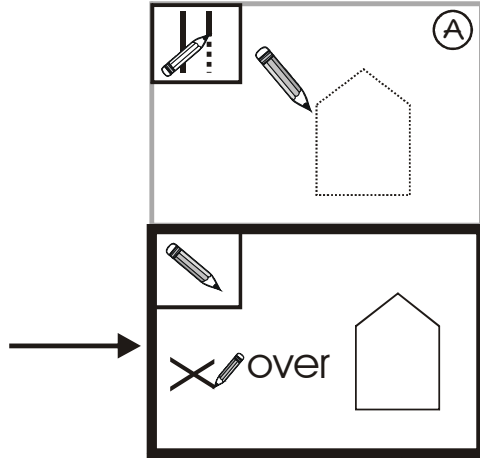

6. Discuss the words ‘over’ and ‘under’. Show students the *Information Sheet* about ‘over and under’.

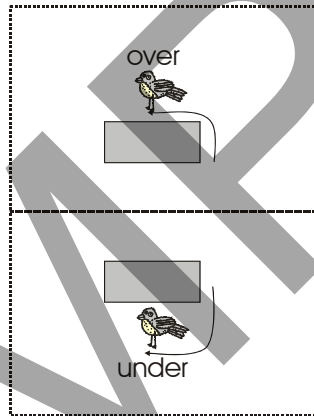

Copy, laminate, and cut out enough birds and boxes for each student to have a set of one bird and one box.

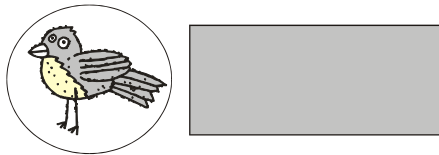

Using the picture of the bird and the box, students practice placing the bird over and under the box.

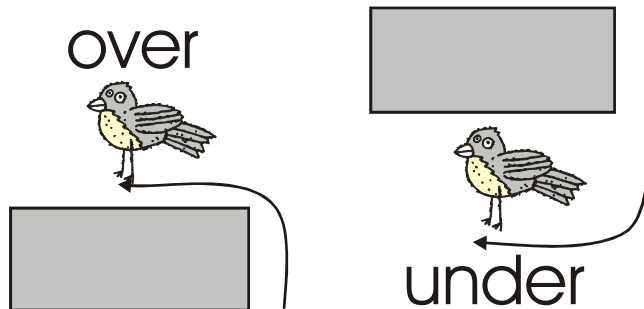

Copy, laminate, and cut out enough **X**'s and house-like shapes for each student to have a set of one **X** and one house-like shape.

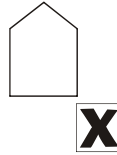

Using the **X** and the house-shaped box, students practice placing the **X** over and under the house-shaped box.

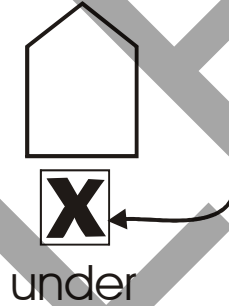
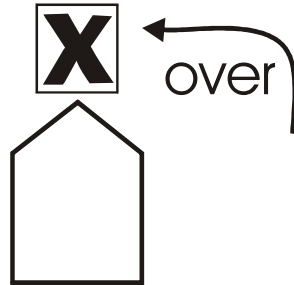

- Before beginning Activity 'B', copy, cut out, and laminate 8 rectangles and 8 ovals for each pair of students. Discuss the concept of patterning. Patterning is the repetition of a set of objects or shapes in a repeated order.

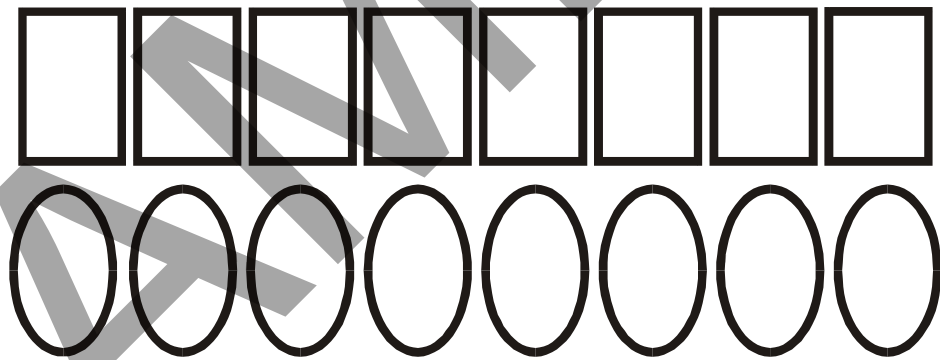

Students practice duplicating the patterns in 'B' that will appear during Week 1.

Day 1

Day 2

Day 3

Day 4

8. In Activity **C**, students count the dog(s), look at the numeral **'1'**, and the word **'one'**.



Students will write the number **'1'** in the **C**-section of their paper at least five times or on all of the dotted figures on the answer sheet.

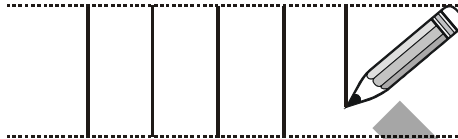

OR

Duplicate the number-writing page for each student. Students then use them to trace the number **'1'** for the **C**-section of their paper. Tell them to start the number at the dot indicated by the pencil and stop their writing at the *Stop sign*.

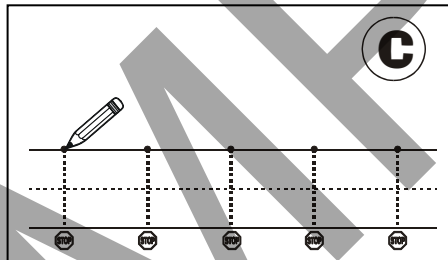

9. Discuss Activity **D**'s directions cards for Week 1



means draw one of the pictured objects



means glue one of the pictured objects



means outline one of the pictured objects.

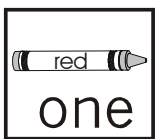

means color one of the pictured objects (e.g. happy face) the color written on the crayon (e.g. red). If this is too difficult, students can just color the pictured object any color.

Daily Activity Sheets for the Week



Day #1

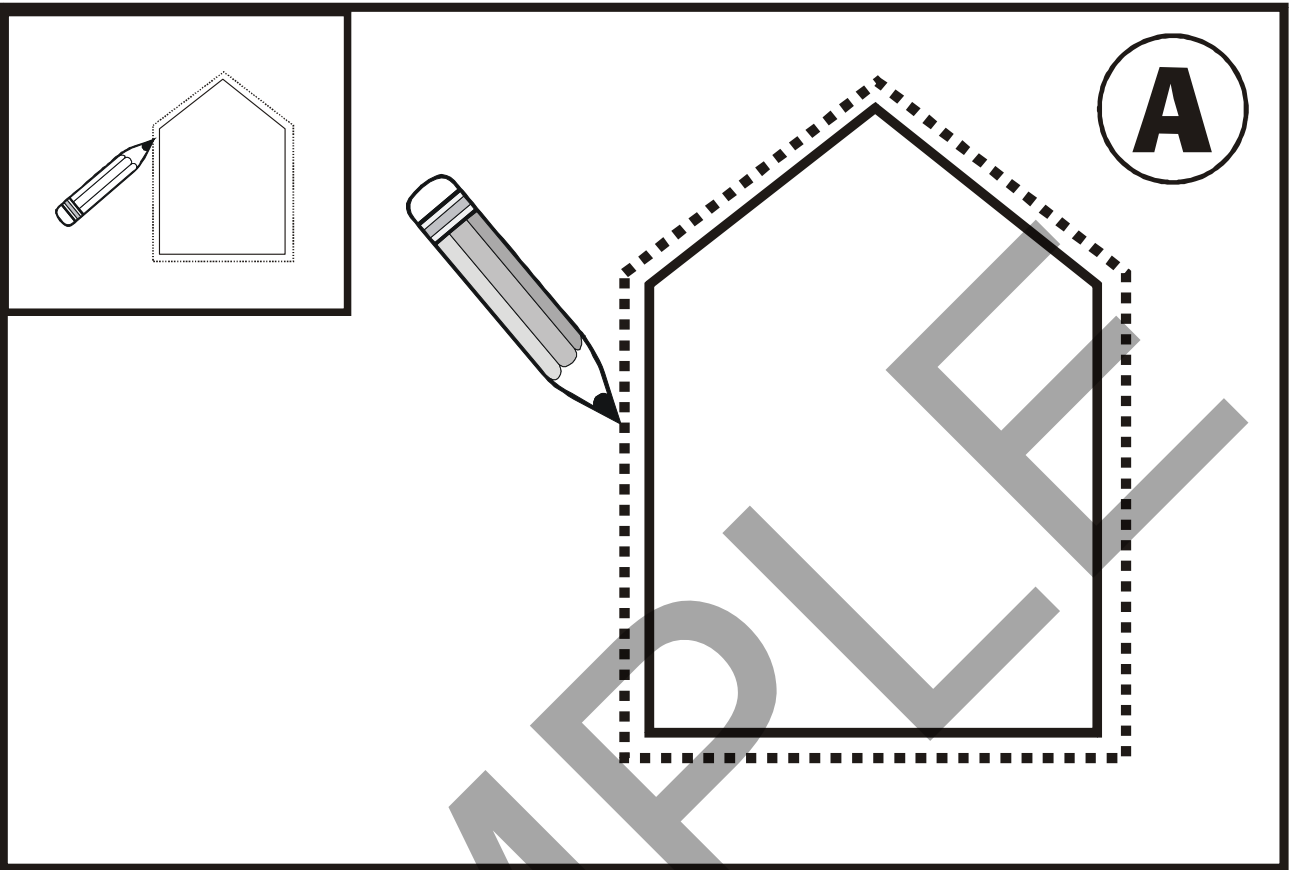

This section contains a tracing guide for the uppercase letter 'A'. In the top-left corner, a small box shows a pencil drawing a dotted outline of the letter 'A'. In the top-right corner, the letter 'A' is enclosed in a circle. The main area features a large dotted outline of the letter 'A' with a pencil positioned at the top-left corner, ready to begin tracing.

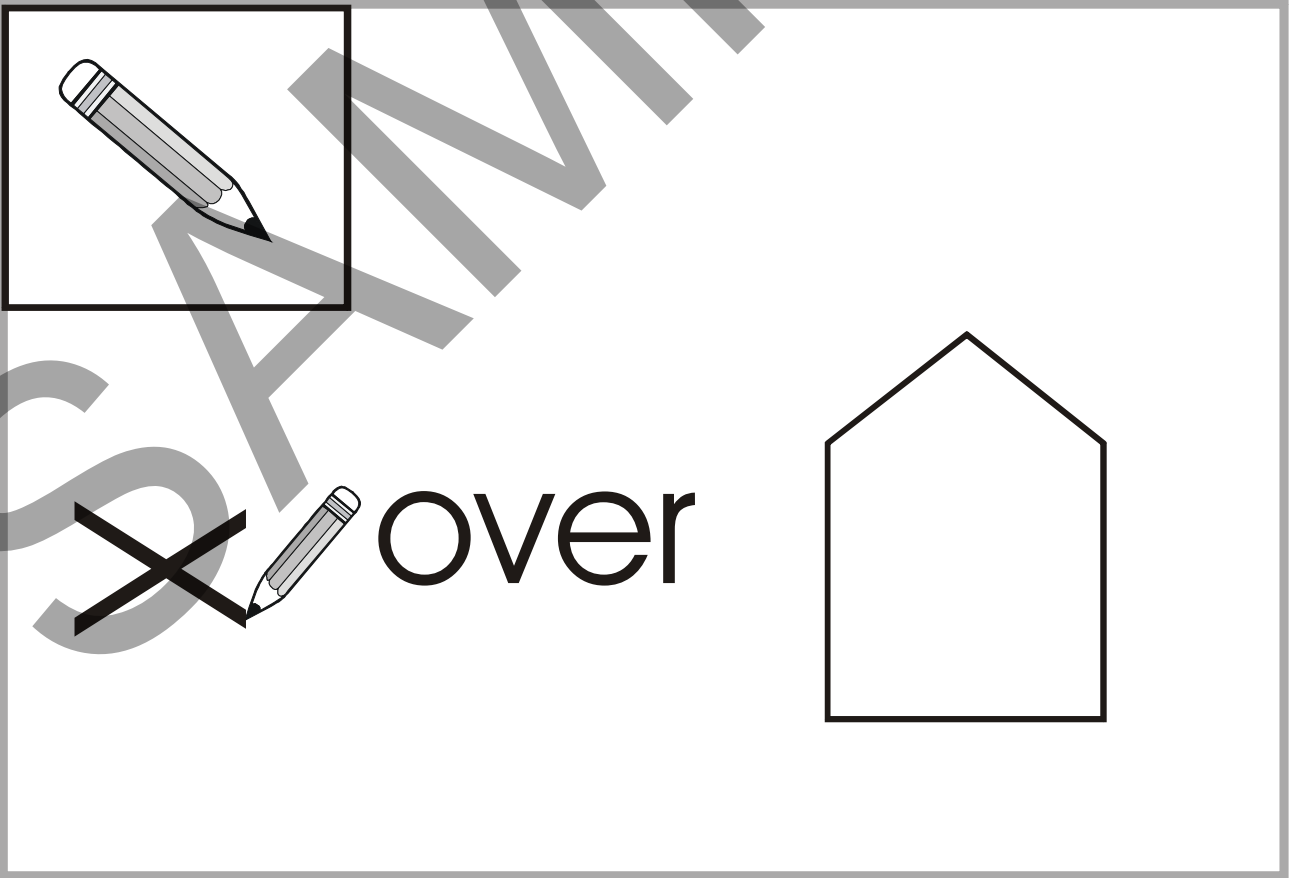

This section is for independent writing practice. It includes a small box in the top-left corner with a pencil. Below this, the word "over" is written in a large, simple font. To the left of the word "over", there is a large 'X' and a pencil icon. To the right of the word "over", there is a solid outline of the uppercase letter 'A' for tracing or copying.

Day #1

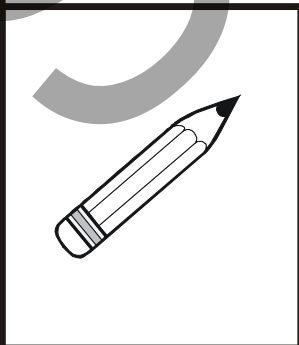
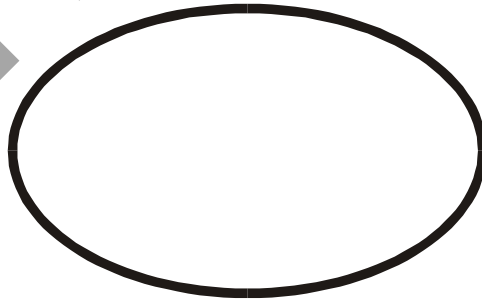
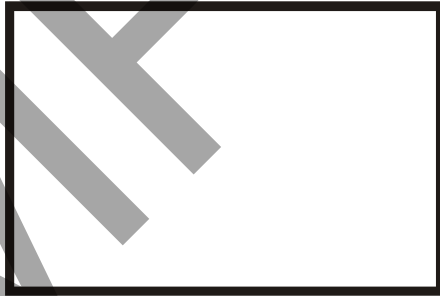
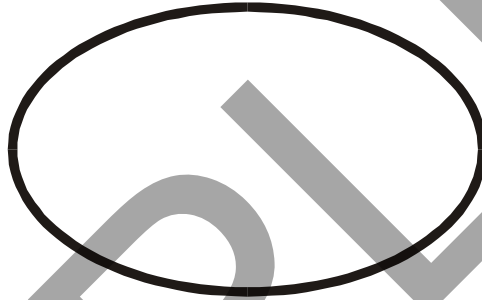

Day #1



I

one



A large writing practice area consisting of five horizontal lines between two vertical dotted lines. A pencil is positioned at the top right, pointing towards the first line. The lines are intended for practicing the letter 'I'.

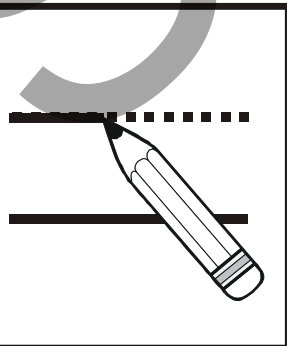



one

Day #1

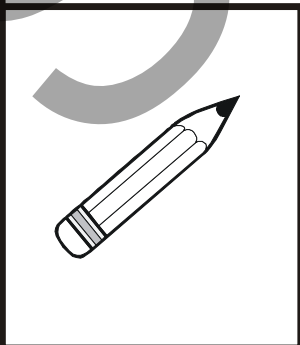

Day #2

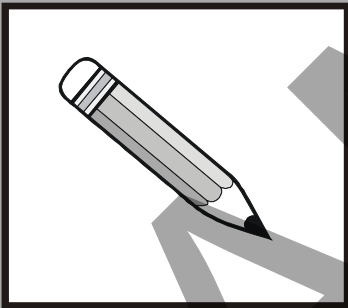
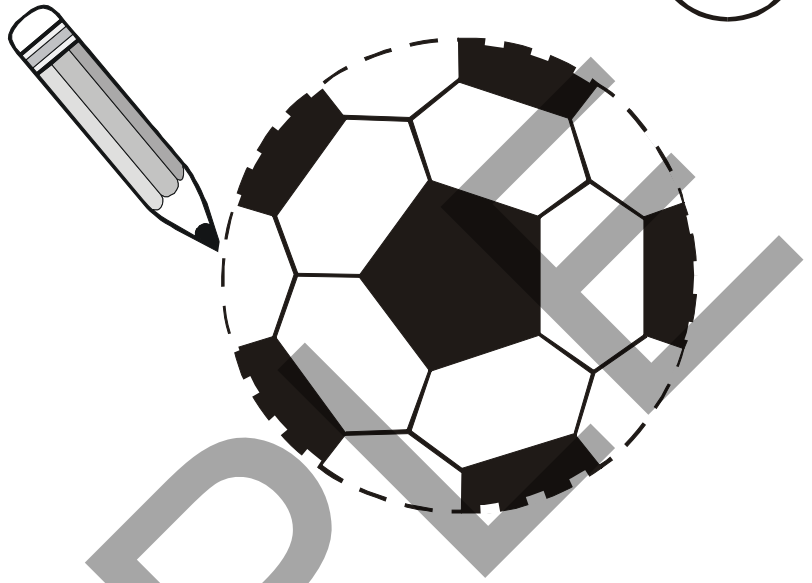
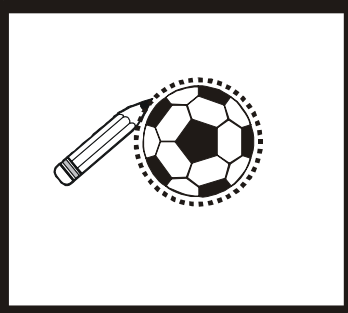

over



Day #2

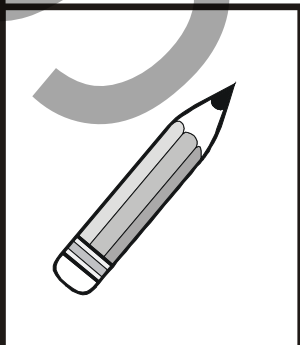
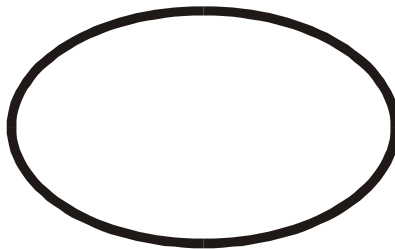
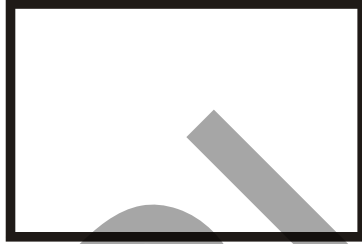
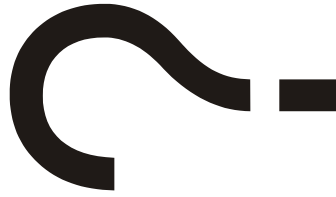

Day #2



1

one

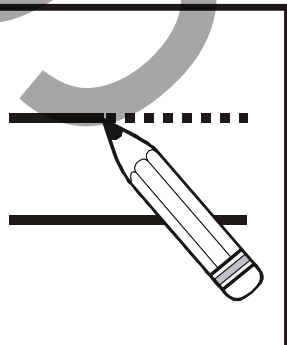
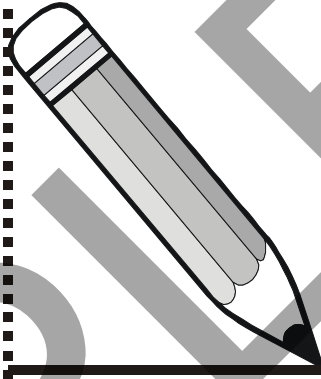
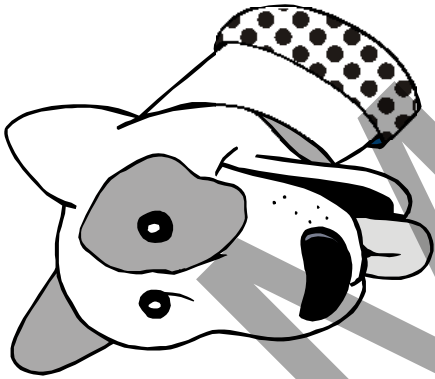

Handwriting practice lines consisting of a solid top line, a dashed middle line, and a solid bottom line. The number 1 is written on the top line, and the rest of the lines are blank for practice.



one

Day #2



one

Day #3

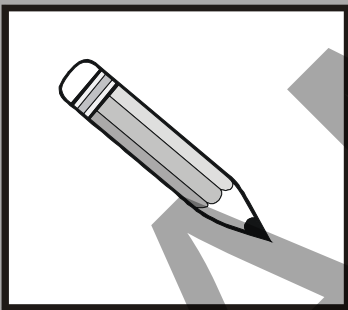
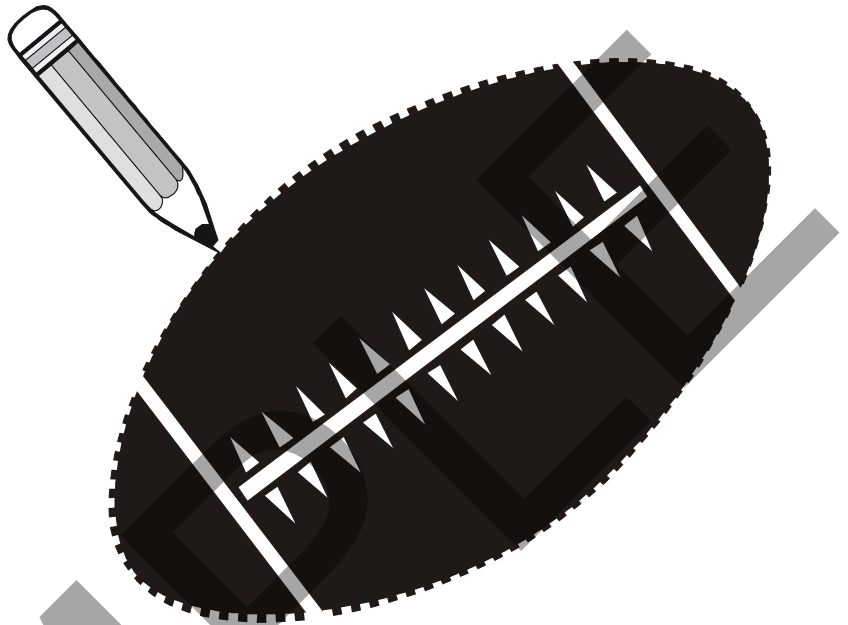
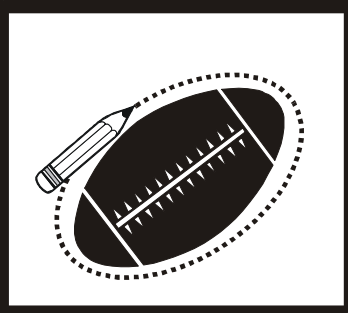

over

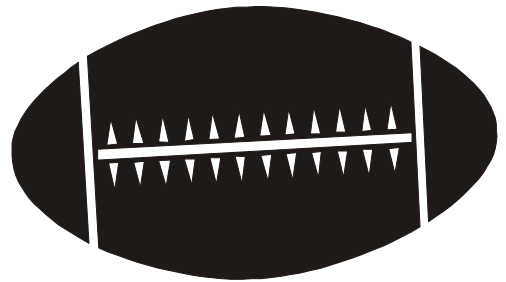

Day #3

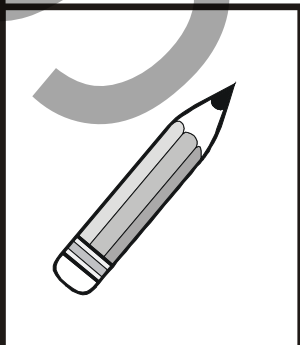
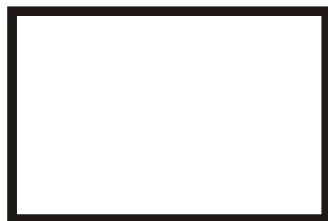
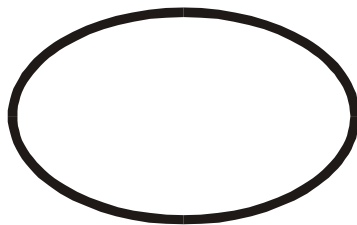
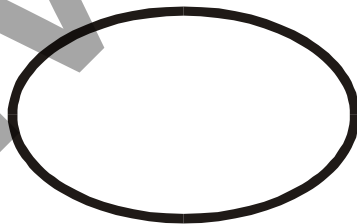
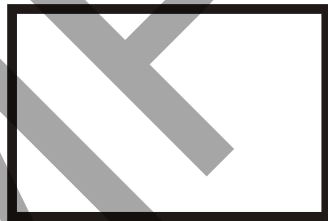
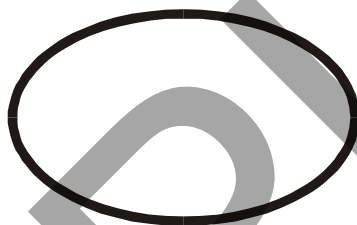
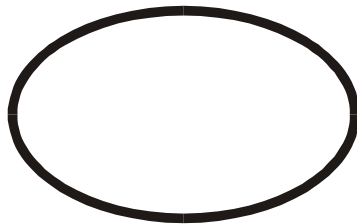
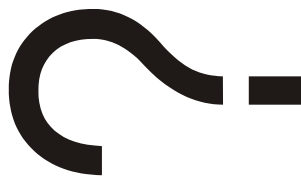

Day #3



1

one

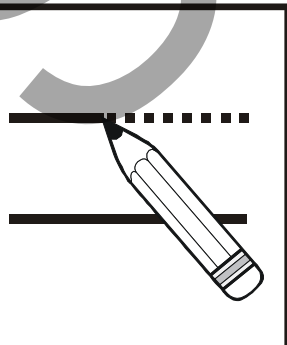
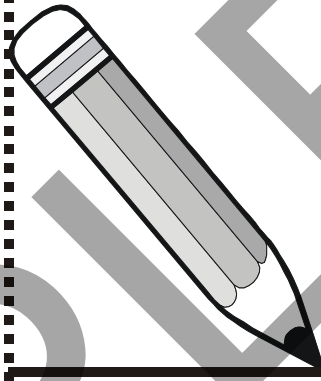
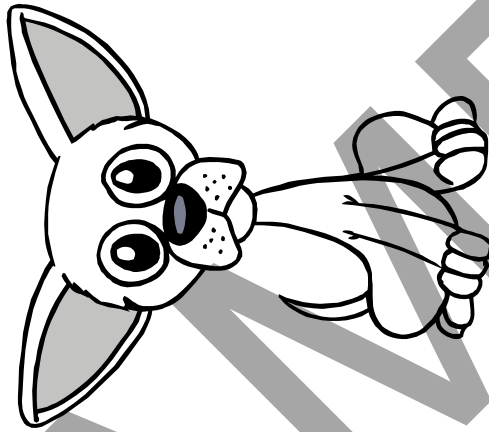



one

Day #3

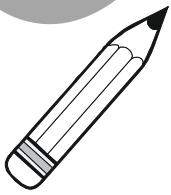

one

Day #4

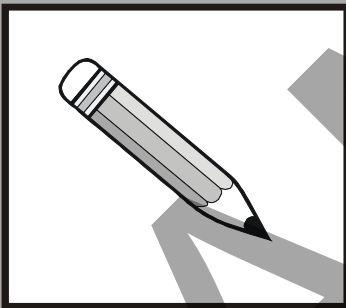
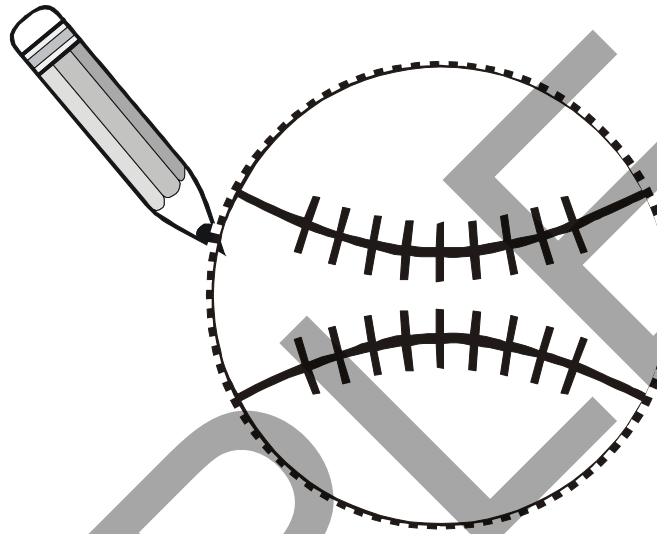
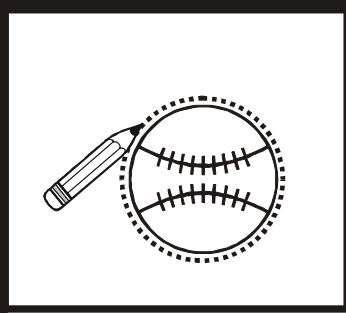

over

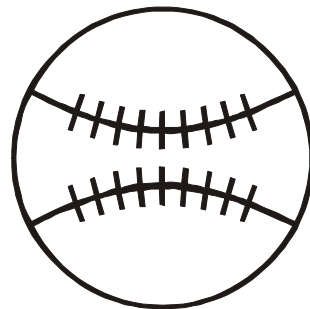

Day #4

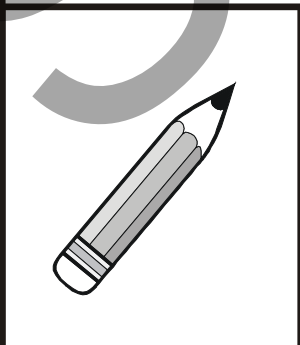
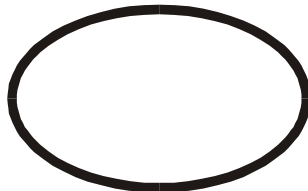
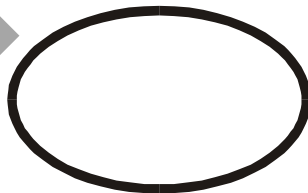

Day #4



1

one

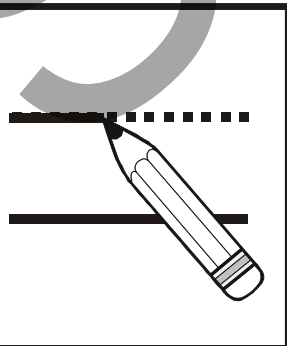
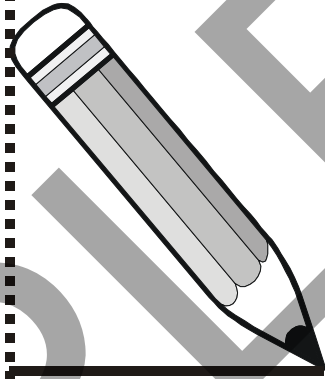



one

Day #4

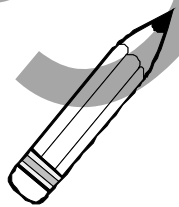

one

Templates for the Week

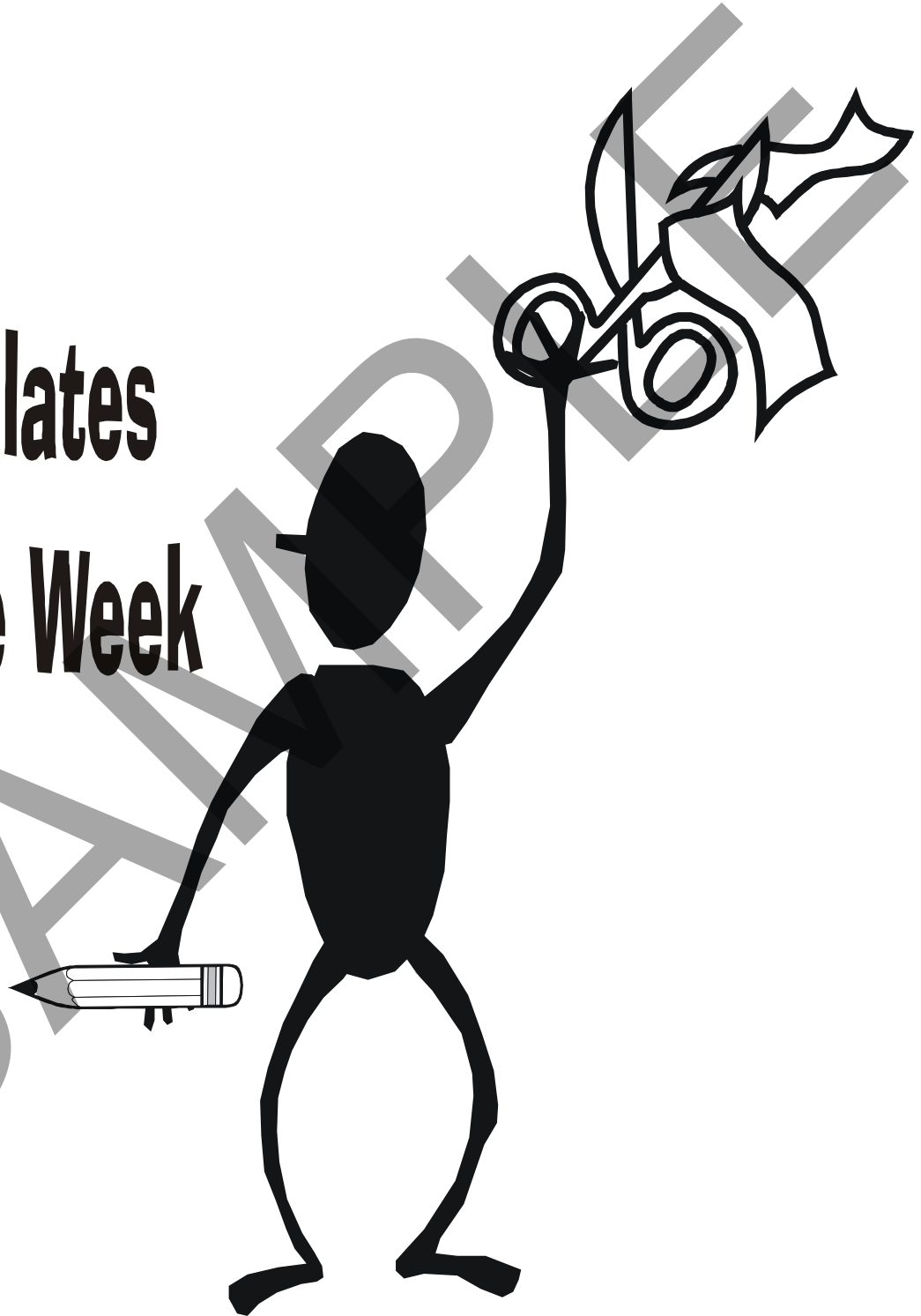

Direction Cards

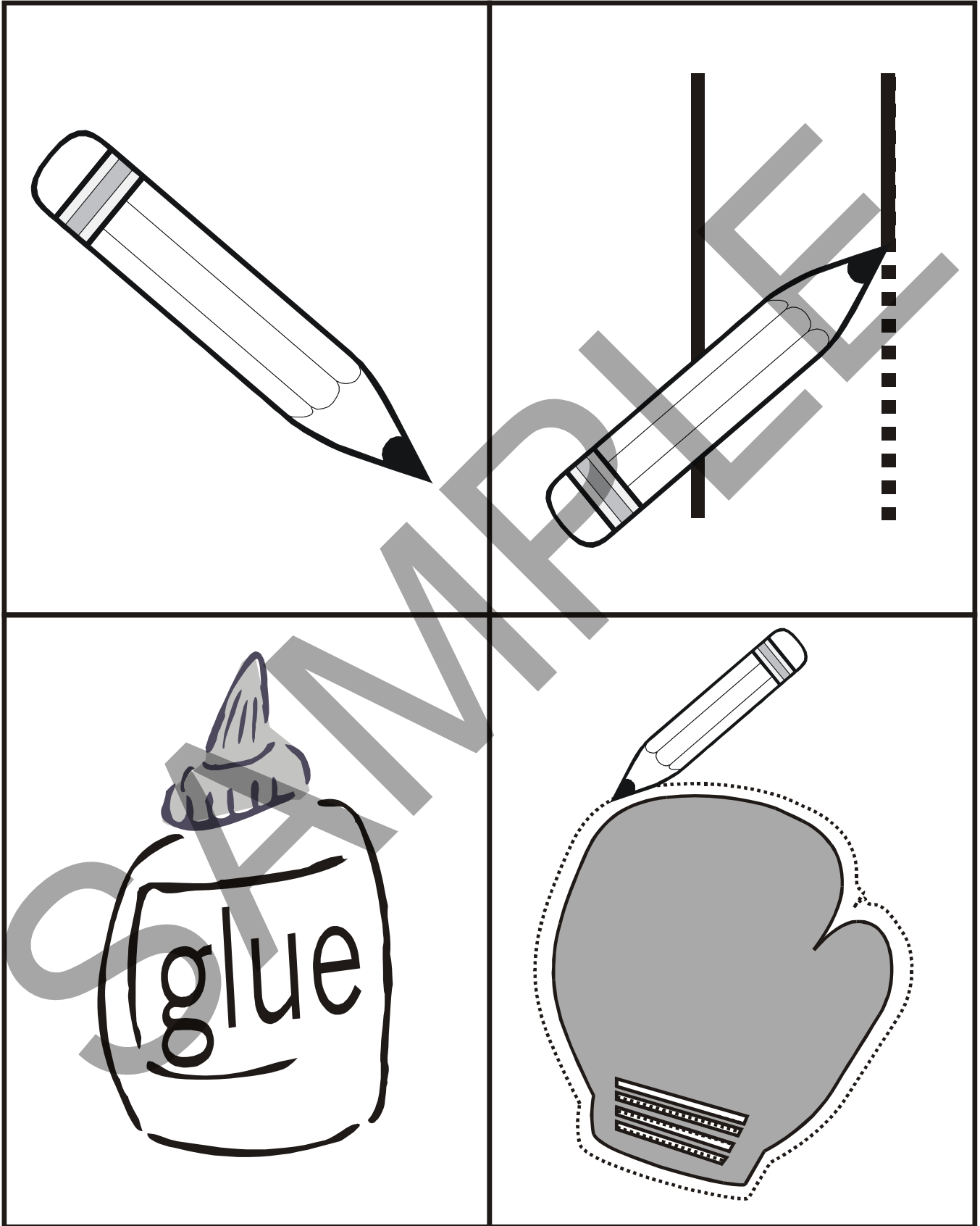

over

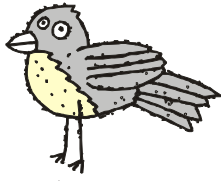
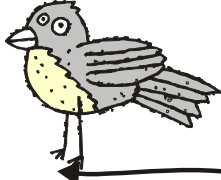

under

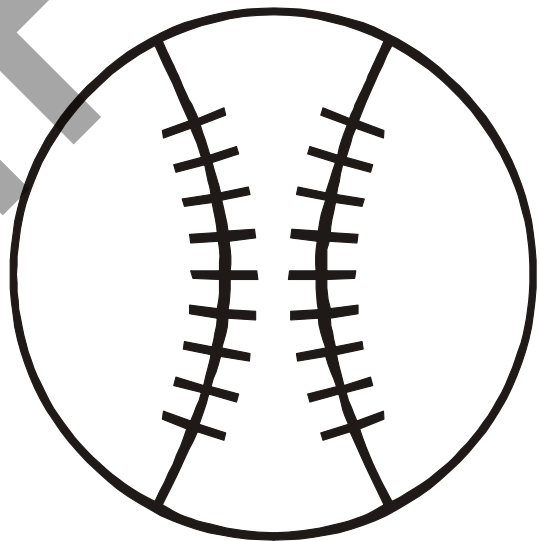
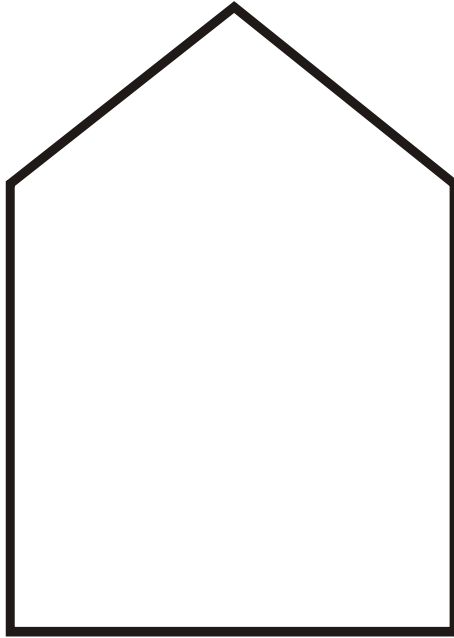

stencils for
A

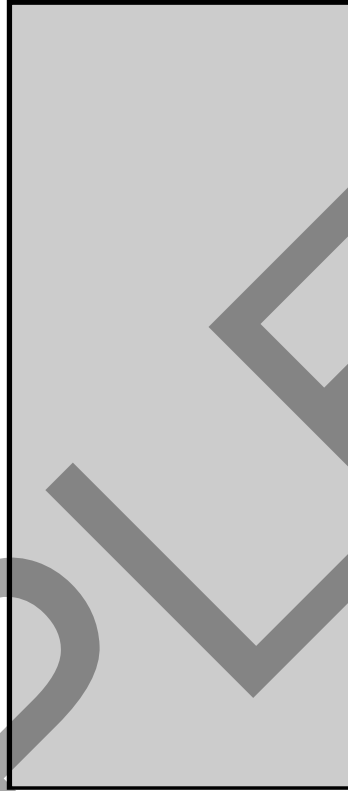
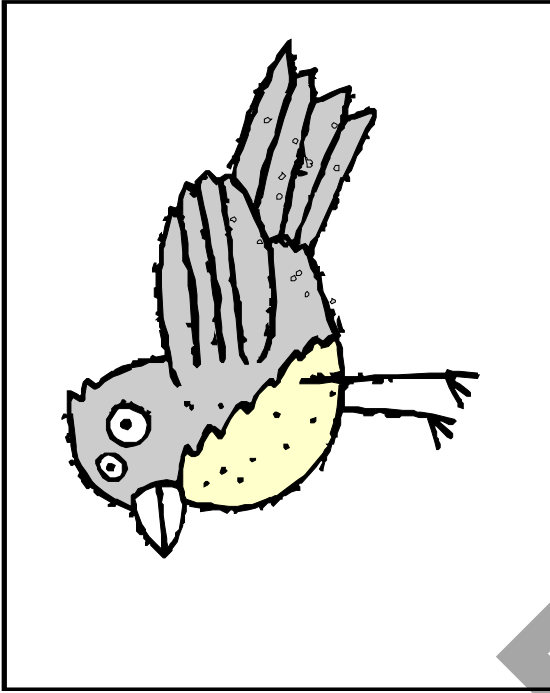

stencil for practice with **A**

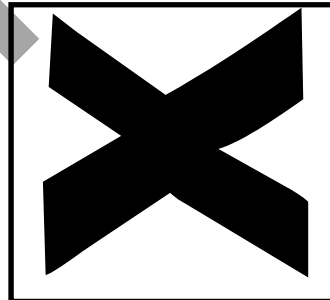



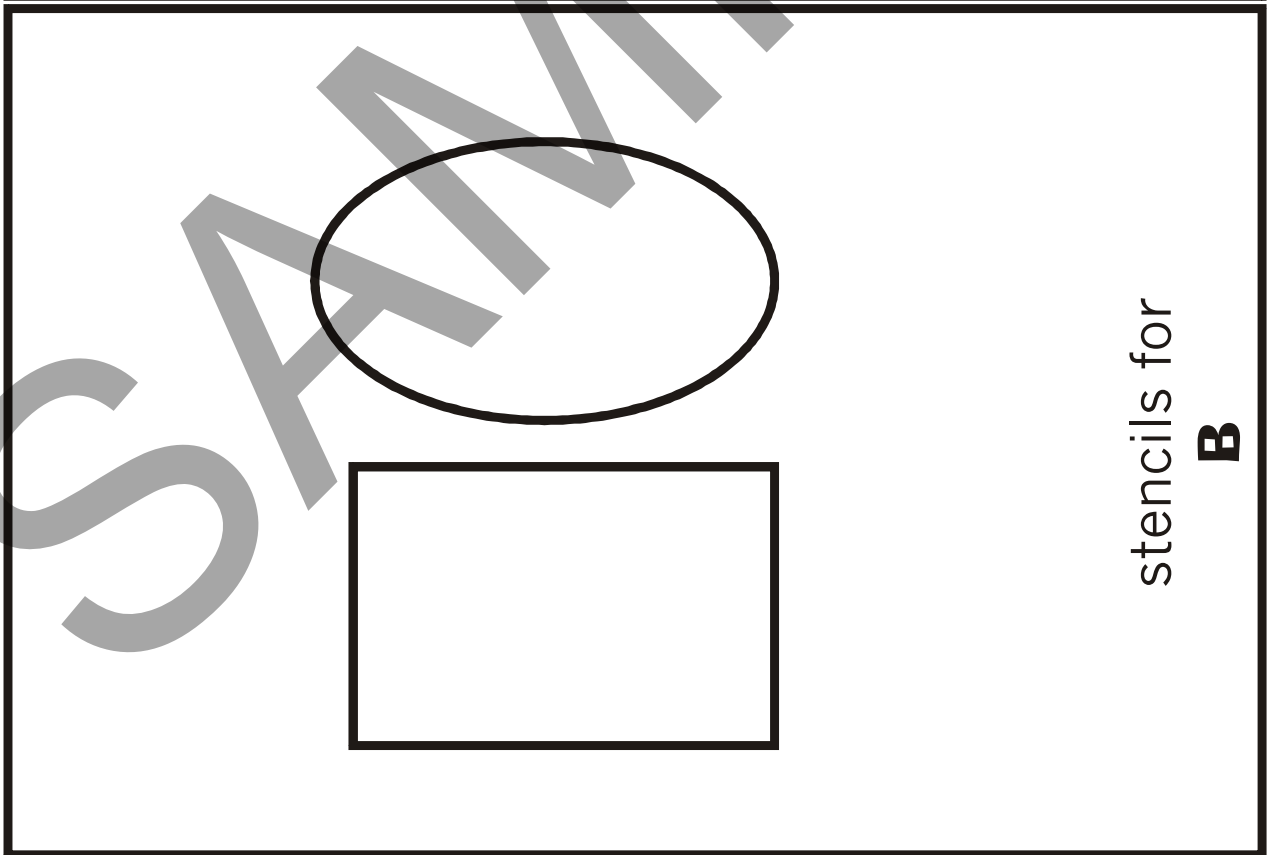
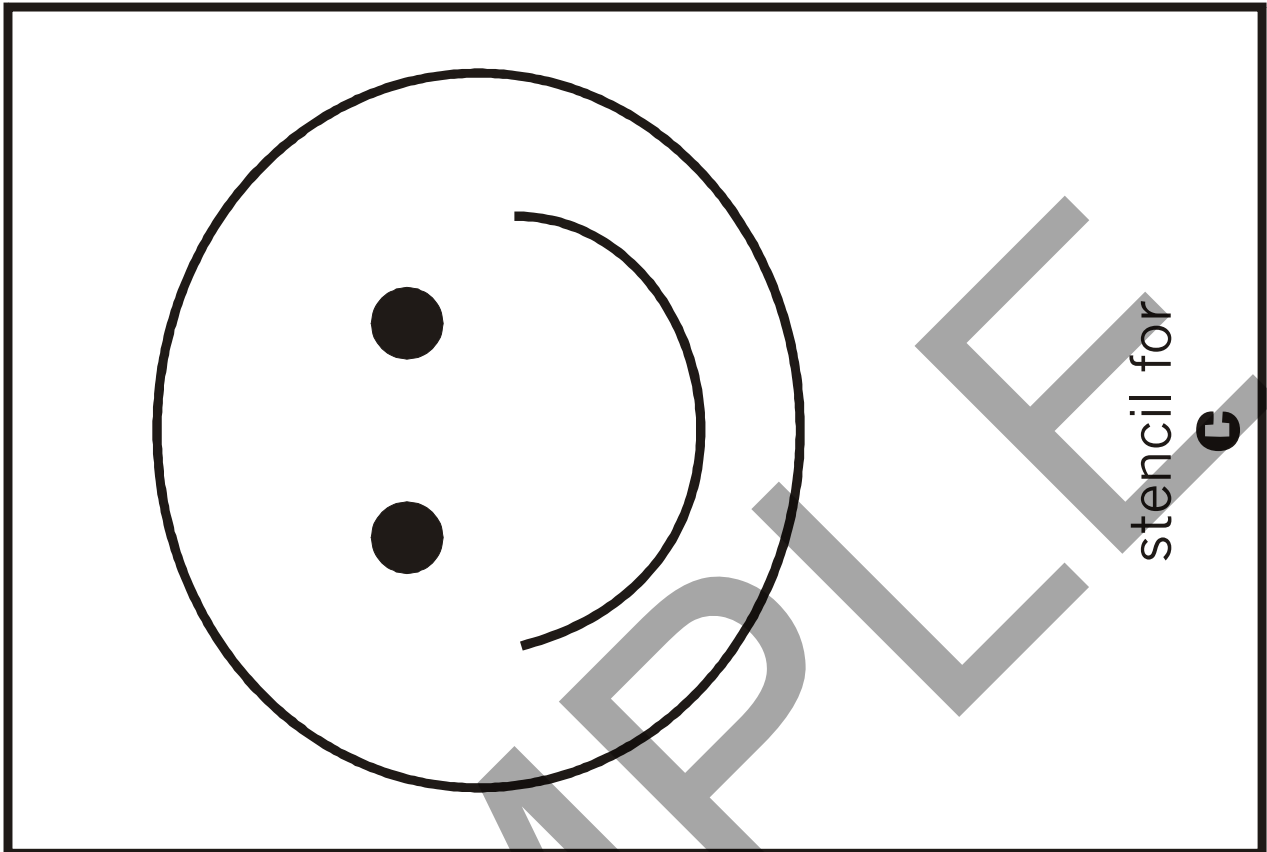

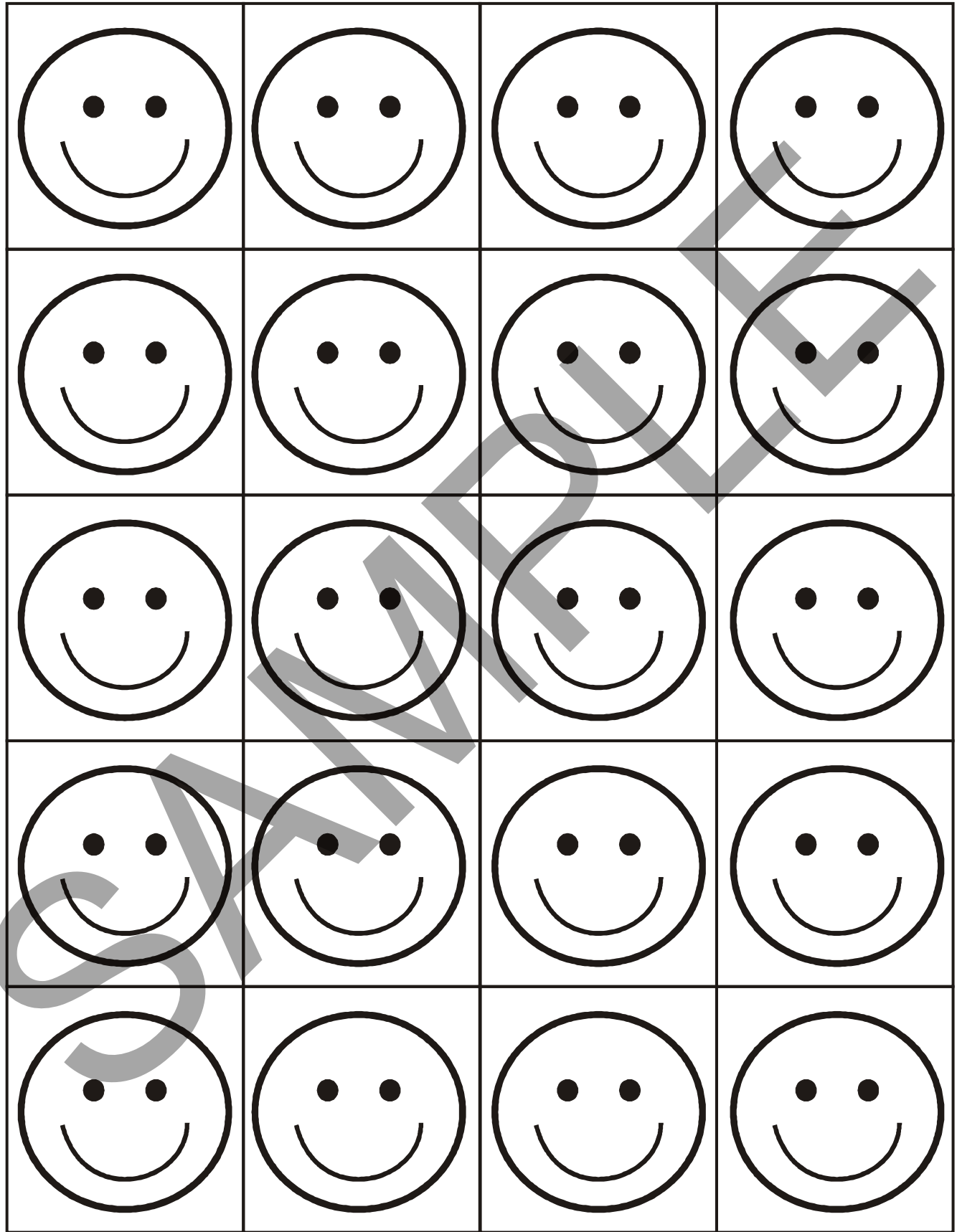

stencil for practice with **A**











The image shows a handwriting practice sheet for the letter 'C'. It is divided into two identical horizontal sections. Each section contains five vertical dashed lines for tracing. Each line starts at a solid black dot on the top solid line and ends at a 'STOP' sign on the bottom solid line. A pencil icon is positioned at the top of the first dashed line in each section. In the top right corner of each section, there is a large, bold letter 'C' enclosed in a circle. A large, light gray watermark with the word 'SAMPLE' is oriented diagonally across the entire page.



Numbers

zero	
one	
two	
three	
four	
five	
six	
seven	
eight	
nine	
ten	

Number Information Sheet for Math Centers

9	nine	
8	eight	
7	seven	
6	six	
5	five	
4	four	
3	three	
2	two	
1	one	
0	zero	

Answers for the week**Day 1:**

- A.** outline rectangle & draw X over box
- B.** draw rectangle
- C.** write number one several times
- D.** draw one happy face

Day 2:

- A.** outline soccer ball & draw X over ball
- B.** draw oval
- C.** write number one several times
- D.** draw one sad face



Day 3:

- A.** outline football & draw X over ball
- B.** draw rectangle
- C.** write number one several times
- D.** draw one face

Day 4:

- A.** outline baseball & draw X over ball
- B.** draw one oval (*also accept 2 ovals as an answer*)
- C.** write number one several times
- D.** draw one face

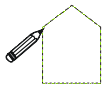
(Front of Answer Sheet for Week 1)

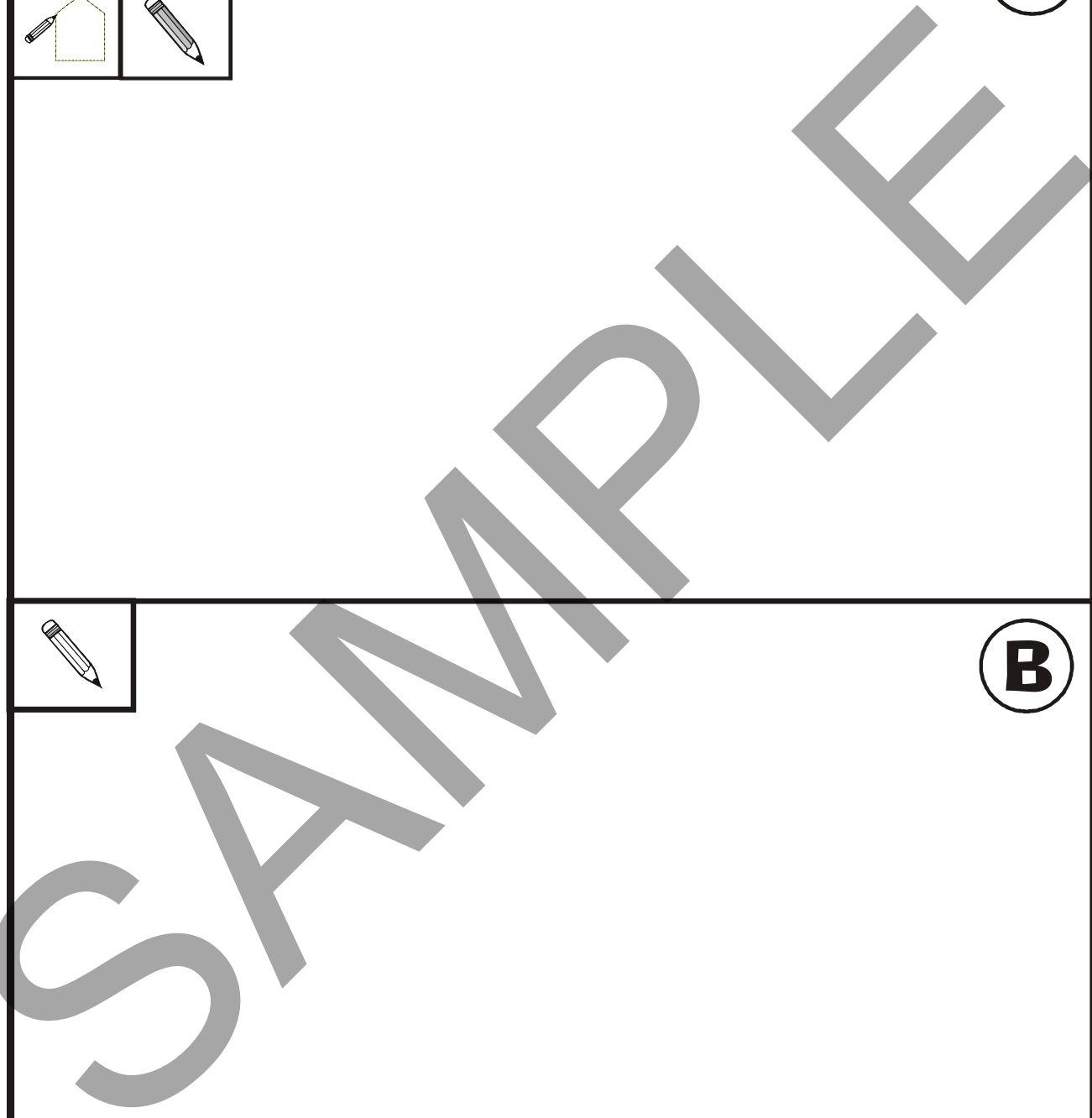
Name: _____		A
		
		B

(Back of Answer Sheet for Week 1)

C

start

D

one

SAMPLE