

Just Write: All Year Long Grade Three

(Part Two: Narrative, & Poetry Writing)

by Kathryn Robinson

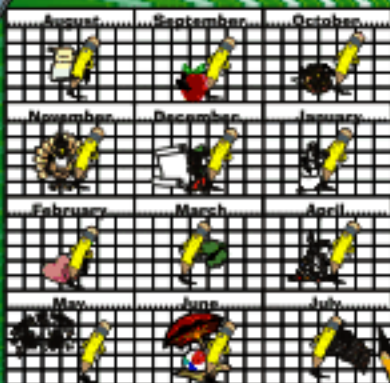

www.writemath.com



WriteMath Enterprises, Inc.
101 E. 14th Street, #200
Minneapolis, MN 55401
612.338.9898



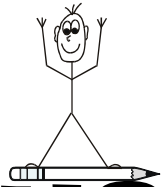

Just Write: All Year Long

(Part Two: Narrative & Poetry)
(3rd Grade)

Kathryn Robinson

Real-World Writing
that
students
understand & love

www.writemath.com

Where Writing 'Counts'®

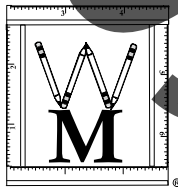

WriteMath Enterprises, Inc.
Valrico, Florida

The student pages in this publication are designed to be used with appropriate duplicating equipment to reproduce copies for classroom use only. WriteMath Enterprises, Inc. grants permission to classroom teachers only to reproduce these student sheets for students in one class per year per book purchased by the school or the teacher him/herself.

Copyright © 2006 WriteMath Enterprises, Inc.
All rights reserved – Printed in the U.S.A.
Published by WriteMath Enterprises, Inc.
3113 Lithia Pinecrest Road., Valrico, FL 33594

Contents

| | |
|--|-------------------|
| Writing Philosophy | VII |
| Contents..... | XXI |
| <i>Introduction to All Year Long Grade 3: Narrative & Poetry</i> | XXVIII |
| <i>Weeks 1-2: Figurative Language</i> | Week 1 page 3 |
| <u>Sentence Work for the Week</u> | Weeks 1-2 page 19 |
| <i>Directions for Sentence Work</i> | Weeks 1-2 page 21 |
| <i>Words for ‘Said’</i> | Weeks 1-2 page 23 |
| <u>Activity Sheets</u> | Weeks 1-2 page 41 |
| <i>Similes Page</i> | Weeks 1-2 page 43 |
| <i>More Similes Page</i> | Weeks 1-2 page 45 |
| <i>Me Page</i> | Weeks 1-2 page 47 |
| <i>Let’s Practice Some Similes</i> | Weeks 1-2 page 49 |
| <i>Practice Some Similes</i> | Weeks 1-2 page 51 |
| <i>Metaphors</i> | Weeks 1-2 page 53 |
| <i>Onomatopoeia</i> | Weeks 1-2 page 61 |
| <i>Alliteration Page</i> | Weeks 1-2 page 63 |
| <i>Alliteration Practice</i> | Weeks 1-2 page 65 |
| <i>Personification Activity #1</i> | Weeks 1-2 page 71 |
| <i>Personification Activity #2</i> | Weeks 1-2 page 73 |
| <i>Personification Activity #3</i> | Weeks 1-2 page 75 |
| <i>Personification Activity #4</i> | Weeks 1-2 page 77 |
| <i>Personification Activity #5</i> | Weeks 1-2 page 79 |
| <i>Personification Activity #6</i> | Weeks 1-2 page 81 |
| <i>Personification</i> | Weeks 1-2 page 83 |
| <i>Week 3: Expository vs. Narrative</i> | Week 3 page 3 |
| Narrative Information | Week 3 page 4 |
| Narrative Bibliography | Week 3 page 19 |
| <u>Sentence Work for the Week</u> | Week 3 page 21 |
| <u>Activity Sheets</u> | Week 3 page 31 |

| | |
|--|-------------------|
| <i>Expository Strips about the Human Body</i> | Week 3 page 33 |
| <i>Narrative Story Strips from <u>Bedhead</u> by Margie Palatini</i> | Week 3 page 35 |
| <i>Expository Strips about Plants</i> | Week 3 page 37 |
| <i>Narrative Story Strips from <u>Just Plain Fancy</u> by Patricia Polacco</i> | Week 3 page 39 |
| <i>Narrative Graphic Organizer</i> | Week 3 page 41 |
| | |
| <i>Week 4: Narrative Planning</i> | Week 4 page 1 |
| | |
| <u>Sentence Work for the Week</u> | Week 4 page 15 |
| | |
| <u>Activity Sheets</u> | Week 4 page 25 |
| <i>Story Ready Graphic Organizer I</i> | Week 4 page 27 |
| <i>Story Strips for <u>Three Little Wolves and the Big Bad Pig</u></i> | Week 4 page 29 |
| <i>Story Strips for <u>Snow White: The Untold Story</u></i> | Week 4 page 31 |
| <i>Story Ready Graphic Organizer II</i> | Week 4 page 33 |
| | |
| <i>Weeks 5-6: Planning a Story with Post-Its</i> | Weeks 5-6 page 1 |
| | |
| <u>Sentence Work for the Weeks</u> | Weeks 5-6 page 37 |
| | |
| <u>Activity Sheets</u> | Weeks 5-6 page 55 |
| <i>Student Sample Introductions for <u>Bad Boys</u></i> | Weeks 5-6 page 57 |
| <i>Student Sample #2 for <u>Bad Boys</u></i> | Weeks 5-6 page 59 |
| <i>Student Sample #3 for <u>Bad Boys</u></i> | Weeks 5-6 page 61 |
| <i>Student Sample #4 for <u>Bad Boys</u></i> | Weeks 5-6 page 63 |
| <i>Student Sample #5 for <u>Bad Boys</u></i> | Weeks 5-6 page 65 |
| <i>Student Sample #6 for <u>Bad Boys</u></i> | Weeks 5-6 page 67 |
| | |
| <i>Weeks 7-8: Narrative Rewriting of a Story</i> | Weeks 7-8 page 1 |
| | |
| <u>Sentence Work for the Weeks</u> | Weeks 7-8 page 29 |
| | |
| <u>Activity Sheets</u> | Weeks 7-8 page 47 |
| <i>'Who' Story Wheel</i> | Weeks 7-8 page 49 |
| <i>'When' Story Wheel</i> | Weeks 7-8 page 51 |
| <i>'Where' Story Wheel</i> | Weeks 7-8 page 53 |
| <i>Character Portrait (front)</i> | Weeks 7-8 page 55 |
| <i>Character Portrait (back for writing)</i> | Weeks 7-8 page 57 |
| <i>Character Trait cards</i> | Weeks 7-8 page 57 |
| <i>Order of Adjectives card</i> | Weeks 7-8 page 65 |
| <i>What is the Order? card</i> | Weeks 7-8 page 67 |
| <i>Adjective cards</i> | Weeks 7-8 page 69 |

| | |
|---|-------------------|
| <i>Story Problem cards</i> | Weeks 7-8 page 73 |
| <i>Narrative Lead Information</i> | Weeks 7-8 page 75 |
| <i>Narrative Introductions page</i> | Weeks 7-8 page 77 |
| <i>Story Topic cards</i> | Weeks 7-8 page 79 |

Weeks 9-10: Writing from a Prompt..... Weeks 9-10 page 1

Sentence Work for the Week..... Weeks 9-10 page 29

| | |
|---|--------------------|
| <u>Activity Sheets</u> | Weeks 9-10 page 47 |
| <i>Short Span of Time Overhead</i> | Weeks 9-10 page 49 |
| <i>Short Span of Time Practice Page</i> | Weeks 9-10 page 51 |
| <i>Haunted House Graphic Organizer</i> | Weeks 9-10 page 53 |
| <i>Narrative Checklists</i> | Weeks 9-10 page 55 |
| <i>Sample Introductions</i> | Weeks 9-10 page 57 |
| <i>Student Introductions</i> | Weeks 9-10 page 59 |
| <i>Narrative Transition Words</i> | Weeks 9-10 page 61 |
| <i>Student Sample Second Paragraph</i> | Weeks 9-10 page 63 |
| <i>Student Sample Third Paragraph</i> | Weeks 9-10 page 65 |
| <i>Student Sample Fourth Paragraph</i> | Weeks 9-10 page 67 |
| <i>Student Sample Climax & Solution</i> | Weeks 9-10 page 69 |
| <i>Sample Conclusions</i> | Weeks 9-10 page 71 |
| <i>Better Than 'The End' Endings</i> | Weeks 9-10 page 77 |
| <i>Student Sample Ending</i> | Weeks 9-10 page 79 |
| <i>Elaboration Practice Pages</i> | Weeks 9-10 page 81 |

Week 11: Writing from a Prompt..... Week 11 page 1

Sentence Work for the Week..... Week 11 page 17

| | |
|---|-----------------|
| <u>Activity Sheets</u> | Week 11 page 27 |
| <i>Birthday Party Graphic Organizer</i> | Week 11 page 29 |
| <i>Sample Introduction</i> | Week 11 page 31 |
| <i>Student Sample Second Paragraph</i> | Week 11 page 33 |
| <i>Student Sample Third Paragraph</i> | Week 11 page 35 |
| <i>Student Sample Fourth Paragraph</i> | Week 11 page 37 |
| <i>Student Sample Climax & Solution</i> | Week 11 page 39 |
| <i>Sample Conclusions</i> | Week 11 page 41 |

Weeks 12-13: Poetry

Weeks 12-13 page 1

Sentence Work for the Week..... Weeks 12-13 page 29

| | |
|--|----------------------|
| <u>Activity Sheets</u> | Weeks 12-13 page 47 |
| <i>Jolly School Bus Driver Graphic Organizer</i> | Weeks 12-13 page 49 |
| <i>Couplets Form</i> | Weeks 12-13 page 51 |
| <i>Haiku Form</i> | Weeks 12-13 page 53 |
| <i>Simile Poem Form</i> | Weeks 12-13 page 55 |
| <i>Switch Poem Form</i> | Weeks 12-13 page 57 |
| <i>Cinquain Form</i> | Weeks 12-13 page 59 |
| | |
| <i>Appendix A: How to Set Up a Prompt</i> | Appendix A page 1 |
| | |
| <u>Activity Sheets</u> | Appendix A page 15 |
| <i>Two Types of Writing Sheet</i> | Appendix A page 17 |
| <i>Expository Terms</i> | Appendix A page 19 |
| <i>Narrative Terms</i> | Appendix A page 21 |
| <i>Expository Box Cards</i> | Appendix A page 23 |
| <i>Narrative Mountain Cards</i> | Appendix A page 25 |
| <i>Prompt Activity I</i> | Appendix A page 27 |
| <i>Writing Prompts</i> | Appendix A page 29 |
| <i>Prompt Activity II</i> | Appendix A page 31 |
| <i>Writing Prompts</i> | Appendix A page 33 |
| <i>Prompt Activity III</i> | Appendix A page 35 |
| <i>Expository Writing Question</i> | Appendix A page 37 |
| <i>Questions Response Cards</i> | Appendix A page 39 |
| <i>Prompt Activity IV</i> | Appendix A page 49 |
| <i>Main Idea Puzzle I</i> | Appendix A page 53 |
| <i>Main Idea Puzzle II</i> | Appendix A page 55 |
| <i>Main Idea Puzzle III</i> | Appendix A page 57 |
| <i>Main Idea Puzzle Pieces</i> | Appendix A page 59 |
| <i>Main Idea Puzzle Pieces for the Response</i> | Appendix A page 61 |
| | |
| <i>Appendix B: Narrative Prompts</i> | Appendix B page 1 |
| | |
| <i>Rubrics & Scoring by Pam Poore</i> | Scored Papers page 1 |

Supporting Writing Material for Students in Grade 3:

1. Just Write All Year Long Grade 3 (*Part One: Expository*)
2. Just Write All Year Long Grade 3 (*Part Two: Narrative*)
3. Just Write: A Sentence
4. Just Write: A Paragraph
5. Just Science Grammar: Grade 3
6. Just Conventions
7. Just Research



For more information:

WriteMath Enterprises
3113 Lithia Pinecrest Rd.
Valrico, FL. 33594
(813) 657-3896

website: www.writemath.com

Just Write:

All Year Long

Grade Three (Part Two: Narrative & Poetry Writing)

by

Kathryn Robinson

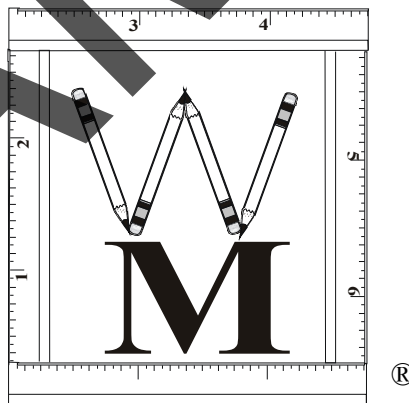

WriteMath Enterprises, Inc.
www.writemath.com

Welcome to

Just Write: All Year Long

Grade 3

(Part Two: Narrative & Poetry)

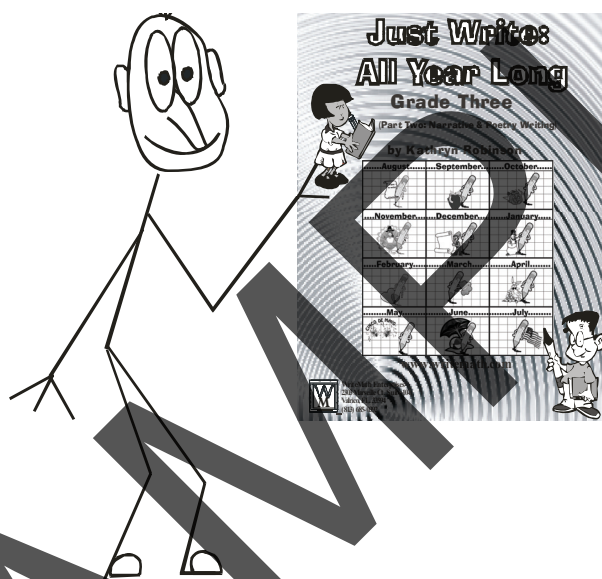

Just Write: All Year Long Grade Three was designed to not only teach writing to young students but to instill a high level of interest in the subject to last a lifetime. The writing suggestions that you find in this book are that: suggestions. They are set up as a guide with a writing objective behind each skill. The writing lesson is not dependent upon the science or social studies topic. The lessons were designed to fit any curriculum area desired.

The overall curriculum plan covers 33 weeks of lessons (Part One and Part Two) that include expository writing, narrative writing, friendly letters, descriptive writing, report writing, as well as phonemic awareness activities that tie in spelling, and grammar lessons supported by daily follow up practice. Hands-on brain-based activities are tied to every lesson to totally involve students of all intelligences, levels, English-speaking ability, and writing abilities.

Writing Workshop should last from 45-60 minutes depending on the length of the integrated activity from another curriculum area (e.g. a science experiment, book being read, math lesson held in conjunction with the lesson, etc.) Each lesson should begin with a five-minute *Quickwrite*[™] (See *Introduction*) followed by a step-by-step writing lesson provided in the week's plan.

The lessons are divided in suggested time frames – one week, two weeks, or three weeks. Each week is formatted the same with daily lessons/activities with supplies needed, spelling and grammar activities, and then activity sheets/templates to use during the week's lessons. Bibliographies are provided after some weeks for your use as required. Writing is a difficult activity to master for young writers. Beginning writers should write short periods of time - about 20 minutes and cover one focused lesson at a time. Well-elaborated paragraphs are stretched out over time in order to master specific skills. If children are handed a full paragraph, essay, or story to write in one of two sittings, all they can think about is getting finished rather than mastering any particular skill. Each lesson should have a focused point of instruction, which is practiced for a short time frame and guided from day-to-day. If your students are having difficulty with a concept at any point, the next lessons should provide support with whole group, small group, or individual instruction in the area of concern. Remember this book contains suggestions and recommendations for a developmental writing program for third graders. If more time is needed for a specific concept, take the extra time – but make it enjoyable and meaningful.

All in all the Just Write All Year Long is a fully integrated, well-rounded writing program designed to create proficient writers who enjoy writing for the sake of writing. So enjoy your students and...

Just WRITE!!!

Welcome





Weeks 5 & 6...

...dig into the details of a great story. These weeks' lessons are designed to help young writers explore and rewrite stories based on an author's details. Many developing writers think that as few as one or two sentences are enough elaboration to help a reader build pictures in their minds. Young writers frame the story in their minds neglecting to add enough detail for the reader's imagination to duplicate the same description and events. Through noting the amount of detail that a professional author adds to his/her story, a writer gains insight for the wealth of detail needed to elaborate and illustrate their writing.

Narrative detail involves expressions and beautiful precise language. Through this week's note taking activities your writers will explore the types of adjectives, adverbs, and vocabulary that are part of great imaginative narrative expressions. So let us examine a few great works of art as exploratory lessons into the essence of specific language.

Weeks 5 & 6

Objective: To learn how to use the narrative graphic organizer.

Supplies:

- Bad Boys by Margie Palatini (2003. NY: HarperCollins)
- My Rotten Red-Headed Older Brother by Patricia Polacco (1994. NY: Aladdin Books)
- Story Reading Narrative Graphic Organizer I (*template in Activity Sheets for the Week in Week 4*)
- 11" x 17" white paper
- Yellow 3" x 5" Post-It notes (or 3" x 5" paper and stick glue)
- Overhead copies of Student Sample Introductions and Events #2-6 (*template in Activity Sheets for the Week*)

Days #1 - 2:

1. Distribute 11" x 17" white paper and a half-of-a-pack of Post-It notes to each student.
2. Students place paper horizontally on their desks.
3. Demonstrate drawing the narrative graphic organizer on the paper. Students draw the organizer on their own page (1), (2), (3).

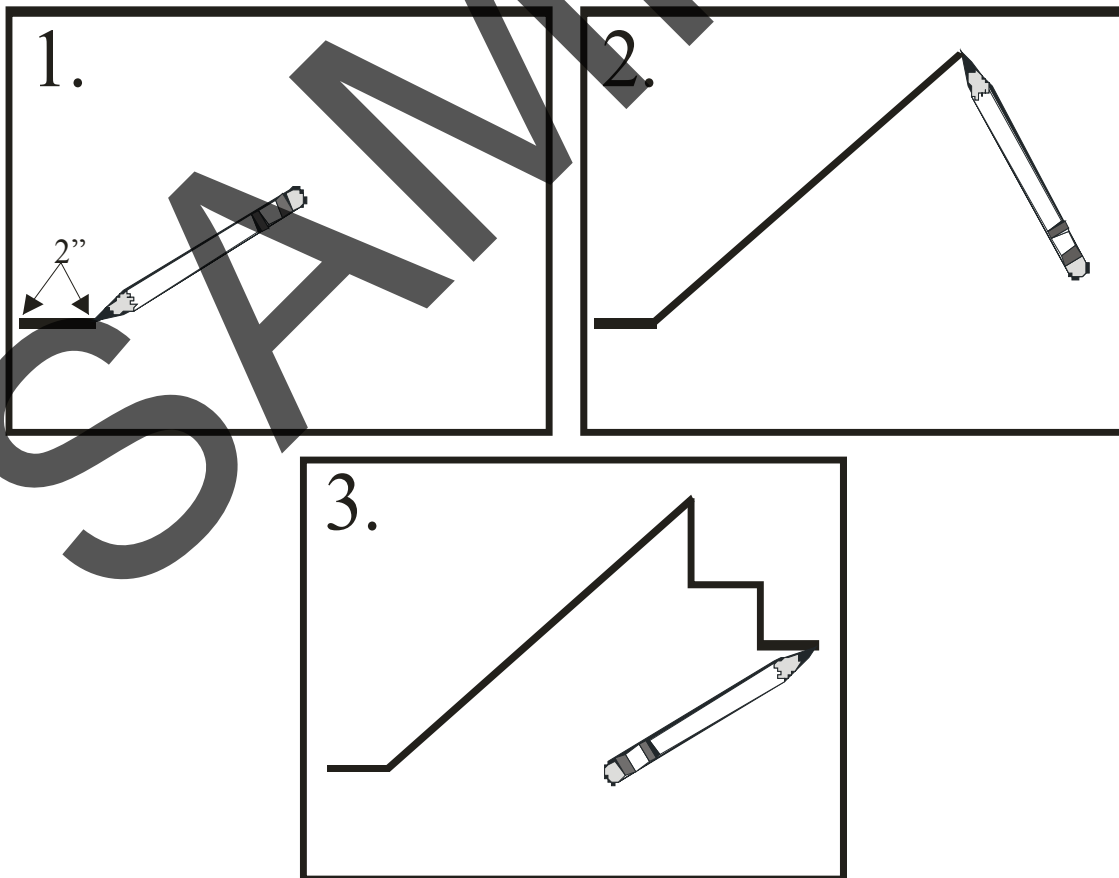

4. Model labeling the parts of the graphic organizer. During this first attempt, you may want the students to use complete words and abbreviations on the next planner. In the left lower corner, students can write *Intro* for Introduction, *Who* for the characters, *When* for the time frame, *Where* for the setting. The Problem/Plot line should be written abutting the line and extending enough to fit a sentence. The most exciting part is the *Climax* and the word (or abbreviation) is written at the peak of the mountain. The excitement then begins to decline as the solution to the problem occurs. A word or abbreviation for Solution should be written below the first step down. The story tapers to a close at the ending. The word or abbreviation for *Ending* is written on the second step down on the graphic organizer. Writers are now ready to begin listening to the story.

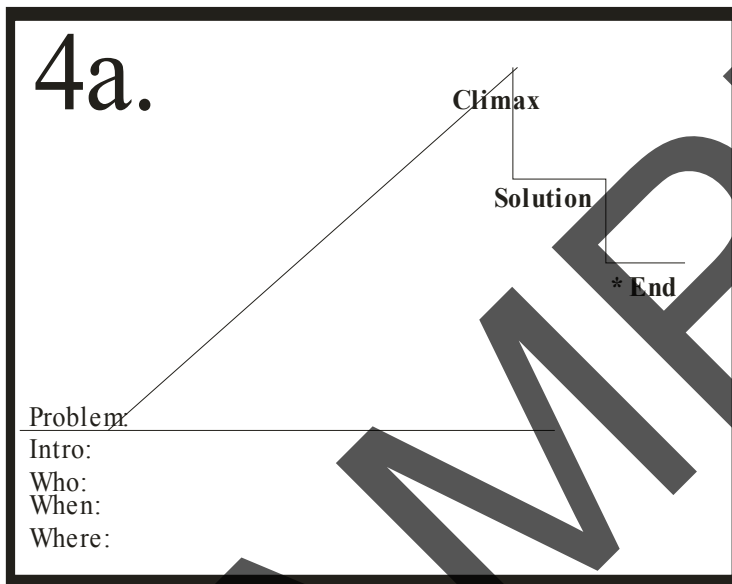

(with words)

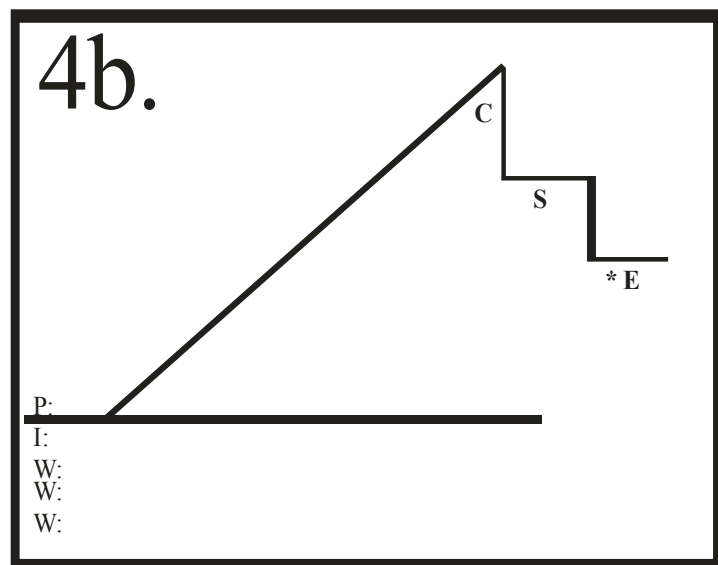

(with abbreviations)

5. Read Bad Boys by Margie Palatini. It is much easier to conduct this activity if the students have previously heard the story. Stop reading after the introduction ending with: “*Oh yeah, we’re bad. We’re bad. We’re really, really bad.*”
- Teacher assists students in completing the *Beginning Portion* of the graphic organizer.
 - ❖ Fill in Who, When, and Where.

Story Reading Narrative Graphic Organizer

Bad Boys
by Margie Palatini

Problem:

Intro: 2 wolves are running away from pigs
 Who: Willy and Wally Wolf
 When: daytime
 Where: field

Climax
Solution
* End

Each event following the introduction becomes more and more exciting as the main character attempts to resolve the problem. Many Fairy Tale plots follow what John Reynolds Gardner states as the classic narrative i.e.: Three attempts to solve a problem, then a climax and problem resolution. Some Fairy Tales have three attempts (or mini-climaxes) after which the reader experiences disappointment in which a resolution to the problem has been attempted by the main character. Each attempt builds the reader’s anxiety level until the final attempt (or climax) occurs and the problem is resolved. After the climax has occurred the reader realizes that the main character has resolved his problem in a positive manner or has resolved to accept his/her situation. The story will then conclude.

6. Students place a post-it on the first event-level of the graphic organizer. I tell students that they are movie producers and the post-its are for the details that we have to make sure are ‘on stage’. For example, the producer would want a ‘*tree in the corner*’, ‘*witch by the candy house*’, etc. I stop after each sentence and ask students what details they heard or key words, such as “...*hadn’t gone far*”, “...*just the person he was looking for.*” Students list details on the post-it from this event ending with “*He ran deeper into the forest until*”. In this story, the students are to look for great details (words or expressions) that third graders do not usually have in their writing. These are the types of words that they need to use to become great writers.
7. Read the story and stop every sentence or two to add details to the post-it notes. For example, after reading, “Ah, yes! The perfect hide-out.” Stop and ask students to recall the words that were important to remember in this part of the story. Guide them towards the words “*out of breath*” because that will help in the retelling of the story. As the story is read, students will become more adept at pointing out the author’s details. When students point out a particular detail, the teacher should write it on the board for them to copy. It is important that they not become concerned with the spelling of the words and forget the details that they wanted to add to the story.

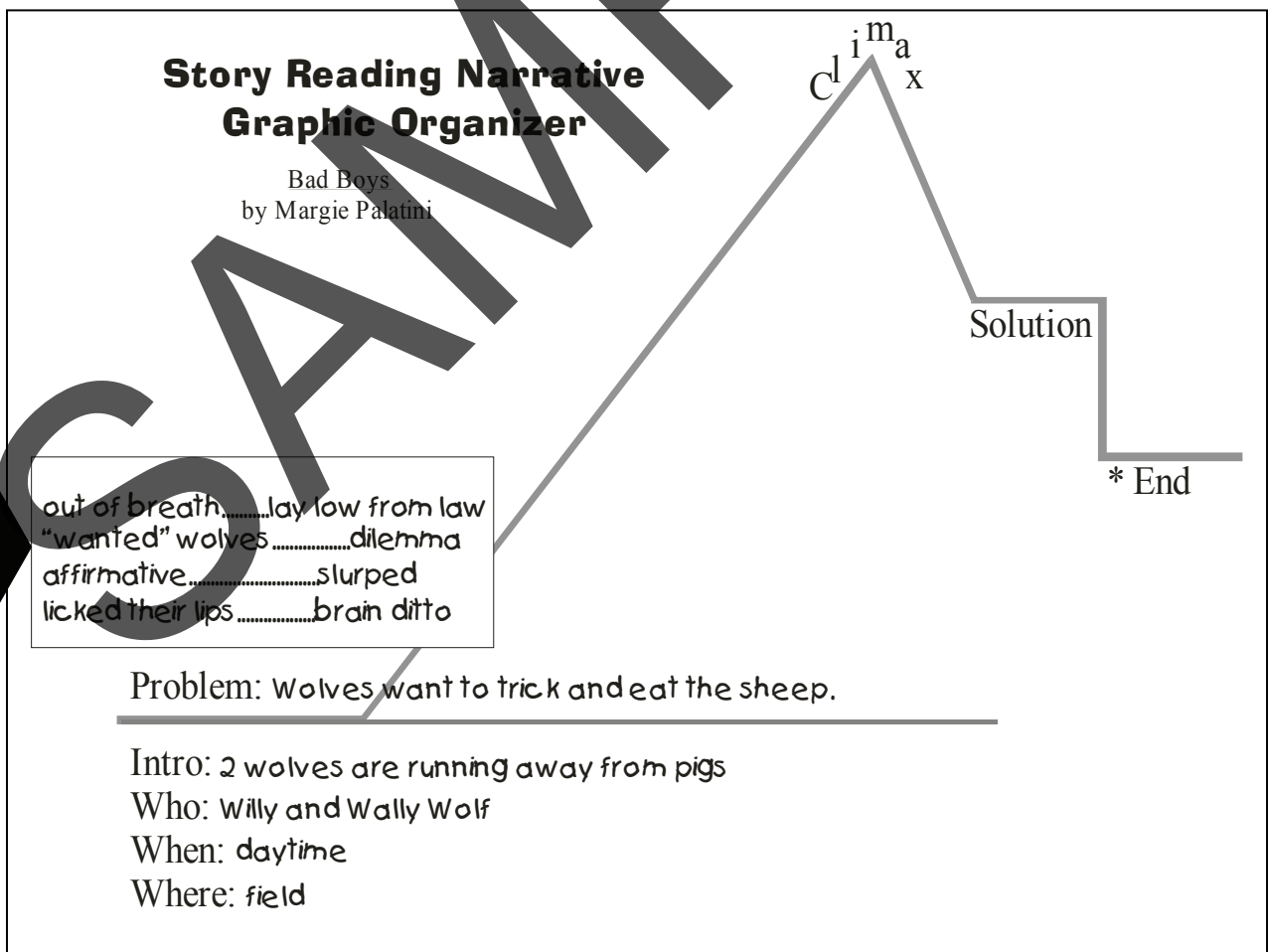

8. After filling in the post-it with details, ask the students how the main character felt at this point of the story. The response might be “hungry”, “excited”, “mischievous”. They write the word that suits the main character’s feeling in the event, as they see it. Showing students how authors infer ideas is an important part of the writing process. Ask students, “Which words from the text let you know that he was scared?” Responses may vary from “*Are you thinking what I’m thinking?*” to “*licked their lips*”.

Story Reading Narrative Graphic Organizer

Bad Boys
by Margie Palatini

out of breath.....lay low from law
 “wanted” wolves.....dilemma
 affirmative.....slurped
 licked their lips.....brain ditto

Feeling: *mischievous*

Problem: Wolves want to trick and eat the sheep.

Intro: 2 wolves are running away from pigs
 Who: Willy and Wally Wolf
 When: daytime
 Where: field

9. The reader now has an inkling of what the main problem in the story might be. Students should ask themselves: *What does the main character(s) want to accomplish in the story?* (What is the story about?) In this case, the main characters want to trick some sheep and eat them. Direct students to write the problem on the line that accommodates this response.

Problem: Wolves want to trick and eat the sheep.

Intro: 2 wolves are running away from pigs
 Who: Willy and Wally Wolf
 When: daytime
 Where: field

10. Students place a post-it on the second event-level of the graphic organizer. As the teacher reads each sentence slowly, students list details on the post-it from the next event ending with the words “*But-sort of adorable.*” It’s important to stop after each sentence and elicit key words or details from the students until they get the idea. Details are specific words that the author uses to create a picture in the reader’s mind. Ask the students to write the complete expression that the author used. Keying in on phrases and clauses helps students raise the level of their own writing rather than just adding good adjectives and adverbs. (e.g.: “...*perfect hide-out*” or “*Fleece the flock...*”)

Climax

eats were included.....on the lam
 pull wool over eyes
 fleece the flock.....bag of tricks
 long-john woolies.....mascara
 twittered.....dainty prance...etc.
 Feeling: proud

out of breath.....lay low from law
 “wanted” wolves.....dilemma
 affirmative.....slurped
 licked their lips.....brain ditto
 Feeling: mischievous

Problem: Wolves want to trick and eat the sheep.

Intro: 2 wolves are running away from pigs
 Who: Willy and Wally Wolf
 When: daytime
 Where: field

**Story Reading Narrative
 Graphic Organizer**
Bad Boys
 by Margie Palatini

* End

After eliciting the feeling for this event, students share the details that they heard in the passage. As students read their details, other writers add new details to their post-it. Students might even count and compare the number of details in each event. They are very proud of the number of details that they recognize in each event. Discuss the repetition of dialogue and characters throughout the story. Focus on the wolves character traits.

11. Students place a post-it on the third event level of the graphic organizer. Students list details independently on the post-it as the teacher reads the next event ending with the words, “...*There’s something very peculiar about you two ewes.*” If the students need more assistance, feel free to model writing the details on the overhead or board after each sentence.
12. Discuss and label the feeling for this event.

Feeling: excited

in clover.....joining the flock
Not to mention
unsuspecting tasty tidbit....morsel
one lick of lamb.....resist
brunch of lawn.....blade.....etc.

eats were included.....on the lam
pull wool over eyes
fleece the flock.....bag of tricks
long-john woolies.....mascara
twittered.....dainty prance...etc.

Feeling: proud

out of breath.....lay low from law
“wanted” wolves.....dilemma
affirmative.....slurped
licked their lips.....brain ditto

Feeling: mischievous

Problem: Wolves want to trick and eat the sheep.

Intro: 2 wolves are running away from pigs
Who: Willy and Wally Wolf
When: daytime
Where: field

**Story Reading Narrative
Graphic Organizer**

Bad Boys
by Margie Palatini

* End

13. Review the details on the post-it. Students turn and share with a partner. Writers add new details as other students are sharing. Discuss the hidden meaning behind the author’s word choice like...”*unsuspecting tasty tidbits,*” “*hoofing up the hill,*” and “*sink his teeth into.*”
14. Teacher calls on students to share their details. Remind students that great writers listen and learn from each other. After listening to one or two students share their details, ask if anyone else has a detail that has not been previously stated. As the students share their ideas, the teacher adds the details to the overhead or board.

15. Students place a post-it over the climax and solution because the two are so closely related that it's difficult to know where one begins and the other ends.

Story Reading Narrative Graphic Organizer
Bad Boys
 by Margie Palatini

Climax

Solution

* End

Feeling: excited

in clover.....
 Not to mention
 unsuspecting tasty tidbit.....morsel
 one lick of lamb.....resist
 brunch of lawn.....blade.....etc.

Feeling: proud

eats were included.....on the lam
 pull wool over eyes
 fleece the flock.....bag of tricks
 long-john woolies.....mascara
 twittered.....dainty prance...etc.

Feeling: mischievous

out of breath.....lay low from law
 "wanted" wolves.....dilemma
 affirmative.....slurped
 licked their lips.....brain ditto

Problem: Wolves want to trick and eat the sheep.

Intro: 2 wolves are running away from pigs
Who: Willy and Wally Wolf
When: daytime
Where: field

16. Students list details on the post-it as the teacher reads the climax and solution ending with the words, "...Oh me, oh my. Totally."

Story Reading Narrative Graphic Organizer
Bad Boys
 by Margie Palatini

Climax

Solution

* End

Feeling: excited

in clover.....
 Not to mention
 unsuspecting tasty
 one lick of lamb.....resist
 brunch of lawn.....blade.....etc.

Feeling: proud

eats were included.....on the lam
 pull wool over eyes
 fleece the flock.....bag of tricks
 long-john woolies.....mascara
 twittered.....dainty prance...etc.

Feeling: mischievous

out of breath.....lay low from law
 "wanted" wolves.....dilemma
 affirmative.....slurped
 licked their lips.....brain ditto

Problem: Wolves want to trick and eat the sheep.

Intro: 2 wolves are running away from pigs
Who: Willy and Wally Wolf
When: daytime
Where: field

blinked.....suddenly gasped.....big eyes
 better to see ewes with.....staring
 big ears.....gulped.....lousy-looking coats
 too cheep for Peep Sheep...3 bags full
 shrugged.....humidity.....damp weather
 can't do a thing with it.....grinned
etc
 naughty naked bid baa-aad wolves

17. After discussing and sharing details, the teacher guides students through sharing the solution. The key that the solution has been reached (a negative one in this case) is that the reader no longer feels that the two wolves are going to attempt to catch the sheep again. They are resigned to their situation and the story is over. I have the students circle the solution (the words: **naughty-naked big baa-aad wolves** - since that is what happened to them) and star the key words that the climax revolves around: **lousy-looking coats**. This will help them later see that these are the types of words that they'll place on their own narrative graphic organizers when they plan their own stories.

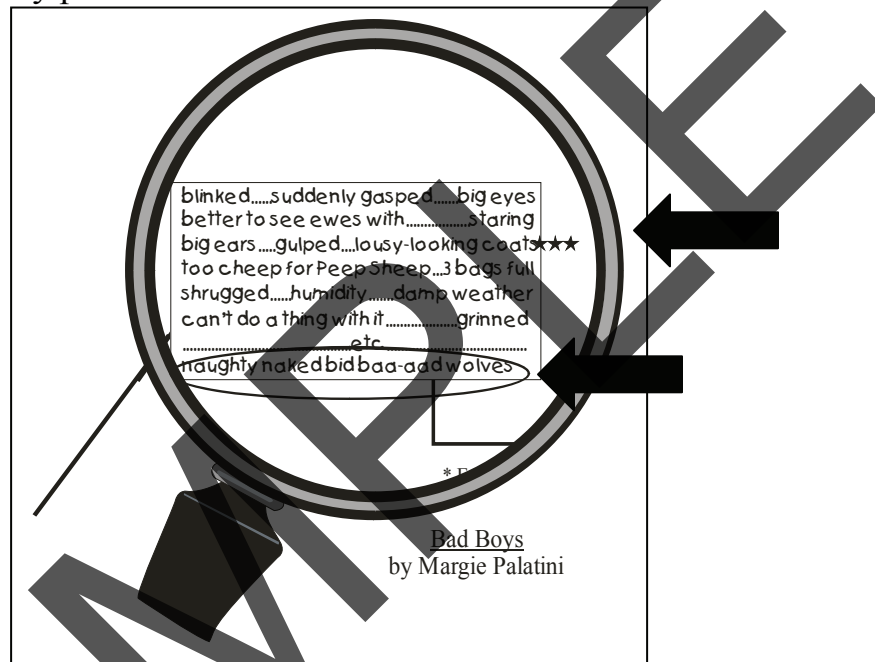

18. Students write a 'feeling' for the main character for the climax and solution.

Feeling: excited

in clover...joining the flock
Not to mention
unsuspecting tasty tidbit...morsel
one lick of lamb...resist
branch of lawn...blade...etc.

Feeling: proud

coats were included...on the lam
pull wool over eyes
fleece the flock...bag of tricks
long-john woolies...mascara
twittered...dainty prance...etc.

Feeling: embarrassed

blinked...suddenly gasped...big eyes
better to see ewes with...staring
big ears...gulped...lousy-looking coats
too cheep for Peep Sheep...3 bags full
shrugged...humidity...damp weather
can't do a thing with it...grinned
...etc...
naughty naked bid baa-aad wolves

* End

Feeling: mischievous

out of breath...lay low from law
"wanted" wolves...dilemma
affirmative...slurped
licked their lips...brain ditto

Problem: Wolves want to trick and eat the sheep.

Intro: 2 wolves are running away from pigs
Who: Willy and Wally Wolf
When: daytime
Where: field

**Story Reading Narrative
Graphic Organizer**

Bad Boys
by Margie Palatini

19. Students place a post-it over the *End* portion of the graphic organizer. Teacher guides the students through listing details on the post-it as the story is read to the end of the book.

Feeling: excited

in cloverjoining the flock
Not to mention
unsuspecting tasty tidbitmorsel
one lick of lambresist
brunch of lawnblade.....etc.

eats were includedon the lam
pull wool over eyes
fleece the flock.....bag of tricks
long-john wooliesmascara
twittered.....dainty prance...etc.

Feeling: proud

out of breath.....lay low from law
"wanted" wolvesdilemma
affirmative.....sturped
licked their lips.....brain ditto

Feeling: mischievous

blinked.....suddenly gasped.....big eyes
better to see ewes with.....staring
big ears.....gulped.....lousy-looking coats
too cheep for Peep Sheep...3 bags full
shrugged.....humidity.....damp weather
can't do a thing with it.....grinned
.....etc.....
naughty naked bid baa-aaad wolves

Feeling: embarrassed

* End

Problem: Wolves want to trick and eat the sheep.

Intro: 2 wolves are running away from pigs
Who: Willy and Wally Wolf
When: daytime
Where: field

**Story Reading Narrative
Graphic Organizer**
Bad Boys
by Margie Palatini

Feeling: excited

in cloverjoining the flock
Not to mention
unsuspecting tasty tidbitmorsel
one lick of lambresist
brunch of lawnblade.....etc.

eats were includedon the lam
pull wool over eyes
fleece the flock.....bag of tricks
long-john wooliesmascara
twittered.....dainty prance...etc.

Feeling: proud

out of breath.....lay low from law
"wanted" wolvesdilemma
affirmative.....sturped
licked their lips.....brain ditto

Feeling: mischievous

blinked.....suddenly gasped.....big eyes
better to see ewes with.....staring
big ears.....gulped.....lousy-looking coats
too cheep for peep sheep...3 bags full
shrugged.....humidity.....damp weather
can't do a thing with it.....grinned
.....etc.....
naughty naked bid baa-aaad wolves

Feeling: embarrassed

thought they had trouble with pigs
headed for the hills.....close shave
wait for hair to growlong time
very bad haircuts

Problem: Wolves want to trick and eat the sheep.

Intro: 2 wolves are running away from pigs
Who: Willy and Wally Wolf
When: daytime
Where: field

**Story Reading Narrative
Graphic Organizer**
Bad Boys
by Margie Palatini

20. Students enjoy counting up the number of details on all of their post-its. I tell them that as a reader I would be so excited about a story that had 10 or 20 details. They are accomplished writers when they can identify the types of details that enliven a piece of writing. They are very proud at the end of this activity.

Ask the students to notice setting at the beginning of the book and again at the end. Point out that this is similar to a prompt: the reader ends up back where he started - in this case, referring to the pigs.

Day #3:

1. Students circle the information on the graphic organizer that belongs in the introductory paragraph: *Who, When, Where, and Introduction.*

Feeling: excited

in cloverjoining the flock
Not to mention
unsuspecting tasty tidbit.....morsel
one lick of lambresist
brunch of lawnblade.....etc.

blinked.....suddenly gasped.....big eyes
better to see ewes with.....staring
big ears.....gulped.....lousy-looking coats
too cheep for peep sheep...3 bags full
shrugged.....humidity.....damp weather
can't do a thing with itgrinned
.....etc
naughty naked bid baa-aad wolves

eats were included.....on the lam
pull wool over eyes
fleece the flock.....bag of tricks
long-john wooliesmascara
twittered.....dainty prance.....etc.

Feeling: proud

out of breath.....lay low from low
"wanted" wolvesdilemma
affirmative.....slurped
licked their lips.....brain ditto

Feeling: mischievous

Feeling: embarrassed

thought they had trouble with pigs
headed for the hills.....close shave
wait for hair to growlong time
very bad haircuts

Problem: Wolves want to trick and eat the sheep.

Intro: 2 wolves are running away from pigs
Who: Willy and Wally Wolf
When: daytime
Where: field

**Story Reading Narrative
Graphic Organizer**
Bad Boys
by Margie Palatini

2. Using this information, students will write a **short** introductory paragraph. If students have difficulty beginning their stories, suggest that they start out with the time frame: daytime. For example, “*It was a sunny, breezy afternoon.*” If a writer addresses at least two of the elements, the third one could be inferred in the story.

- Focusing on the characters, time frame, and setting, students work with a partner to develop the introduction to their retelling of the Bad Boys. Share several introductions verbally before students begin to write it on paper.

Sample Introductions: (template in Activity Sheets for the Week)

The day was hot but the pigs were hotter! Hopping hot and mad at the two big bad boys Willy and Wally Wolf escaping across the field.

Willy and Wally Wolf barely escaped the angry pigs as they took off across Potter's field that blazing hot Friday afternoon.

Who would have thought that two wolves could get in so much trouble – But Willy and Wally Wolf could get in trouble any time of day. It was a Saturday afternoon in May, "Help! Help! Help!" yelled Willy and Wally Wolf as they ran through the cornfield only inches in front of a mad mob of pigs.

Willy and Wally Wolf raced across the cornfield with the pigs close behind. This was going to be a long day.

- Students share their introductory paragraphs.

Days #4:

- Students reread the Introductory Paragraph they wrote the previous day. Revise and edit their work before continuing.
- Students circle the information that will be in the first event/ scene: the first post-it's information and feeling. Students take the post-it off and place it below their Introductory Paragraph on their writing paper. Using the details on the post-it, they rewrite the first event.

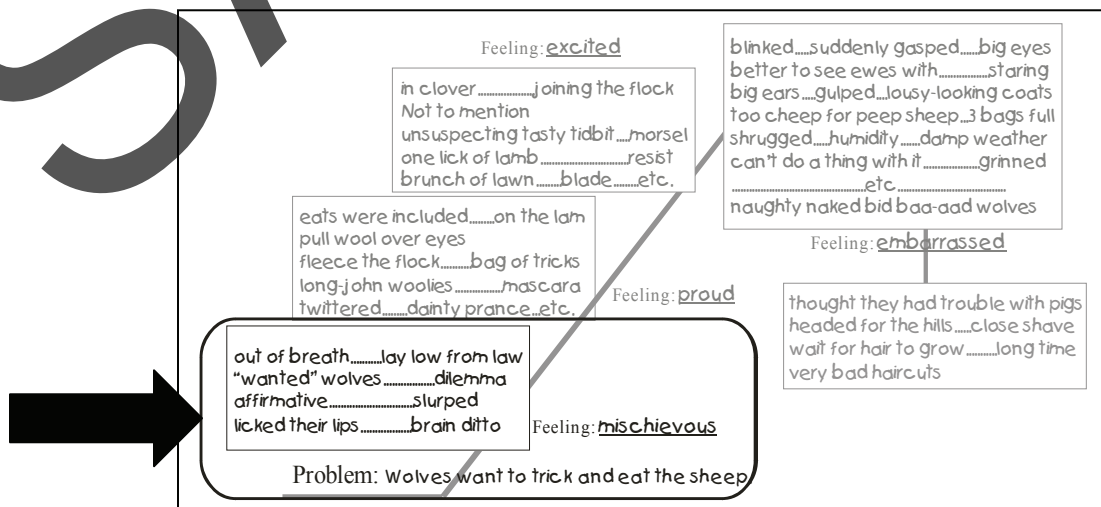

3. Students rewrite this paragraph in their own words. I ask the students to include D.A.D. in each body part: **D**escription, **A**ction, and **D**ialogue. Describe something, or someone in the area, using an assortment of attributes. Writers specify actions occurring. I don't want them to just say, "The wolves relaxed." They should build the story with, "Sucking on a straw filled with Sprite, Wally Wolf relaxed lazily against the fence post." Remind students to infer how the characters are feeling in their writing.
4. When students are rewriting their stories, remind them that authors like Tomie de Paola and others have become famous by rewriting stories in their own way. Remind students that as a writer their creativity, imagination, and own backgrounds could add interesting aspects to the story. This does NOT have to be an EXACT retelling. This retelling was designed to help your writers gain a sense of story and act a guide for their own creations.
5. Students share their paragraphs.

Student Example #2

(template after Sentence Work)

"Wally, I think that we did it! For a while there, I thought that we were goners!" chuckled Willy removing his old dress.

"Not me! I knew that we were far too clever for them," retorted Wally wiping the corn leaves from his pants. "We were just too bad for them!"

Out of breath, the two wolves collapsed on the side of the road and decided to lay low from the law for a while.

"How are we going to hide out, Wally?" questioned Willy relaxing against the fence post and slowly sipping on his drink.

Suddenly, Wally and Willy both jumped up to a delicious sound in the distance, "Baa."

"Did you hear that?" whispered Wally as Willy pushed aside the cornstalks to a herd of sheep heading towards them.

"Are you thinking what I'm thinking?" said Wally as he licked his lips.

"I sure am!" said Willy.

6. Teacher marks cut and paste areas for students to cut apart and elaborate during the following lesson (*explained in detail in Day #5's lesson*).

Days #5:

1. Students reread the first event they wrote the previous day. Revise and edit their work before continuing.
2. Model cutting and pasting. Remind students that this activity replaces rewriting the whole event.
 - a. When I read their work, I often find an area that should have been developed more fully. I employ a technique that I call ‘cut & paste’.

This writer must explain in more detail about the wolf relaxing:

- Where was he relaxing?
- Show me what you mean by relaxing.



...Wally sat down and relaxed there. Willy sat down beside him...

- b. After identifying the deficit area, I draw a line below the underdeveloped sentence with a highlighting marker.

...Wally sat down and relaxed there. Willy sat down beside him...

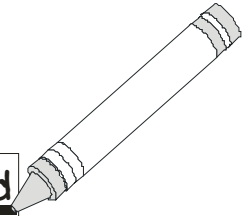

- c. The student (after I modeled ‘*how to cut it correctly*’) cuts the paper apart along the highlighted line..

...Wally sat down and relaxed there. Willy sat down beside him...

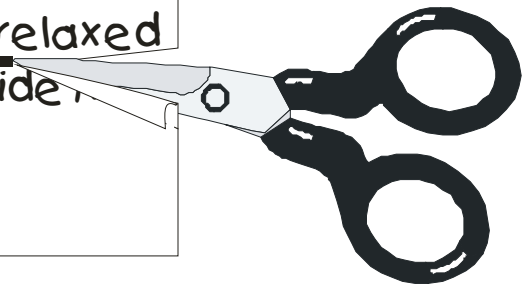

- d. Then he/she glues it to a new piece of writing paper with stick glue. (Bottle glue makes the paper too wet.)

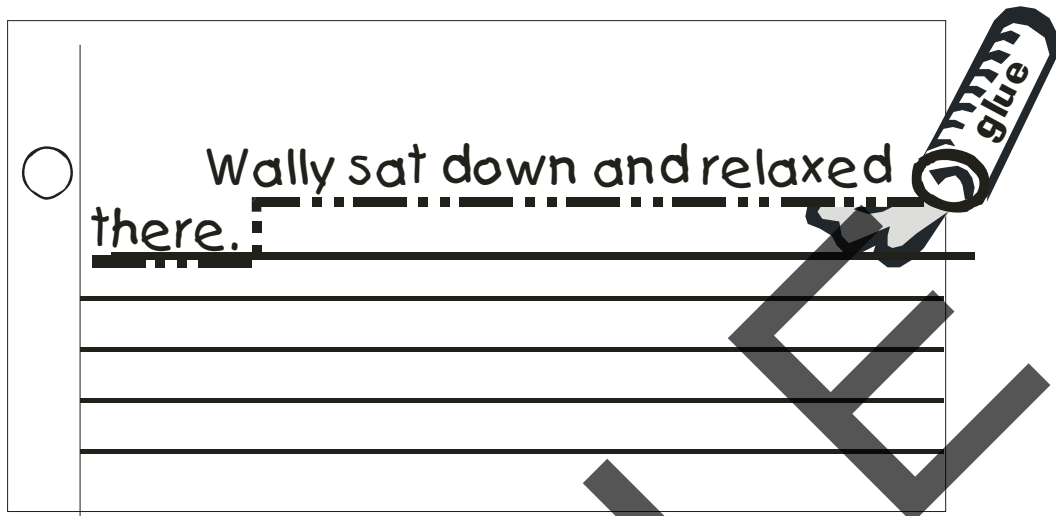

- e. Student adds a couple more sentences elaborating the wolf relaxing. Some students are prone to ramble so I restrict them to 2-3 more sentences about their problems so they will not go 'off-topic'.
- f. After they have developed the writing adequately, they glue the rest of their writing back on to the paper.

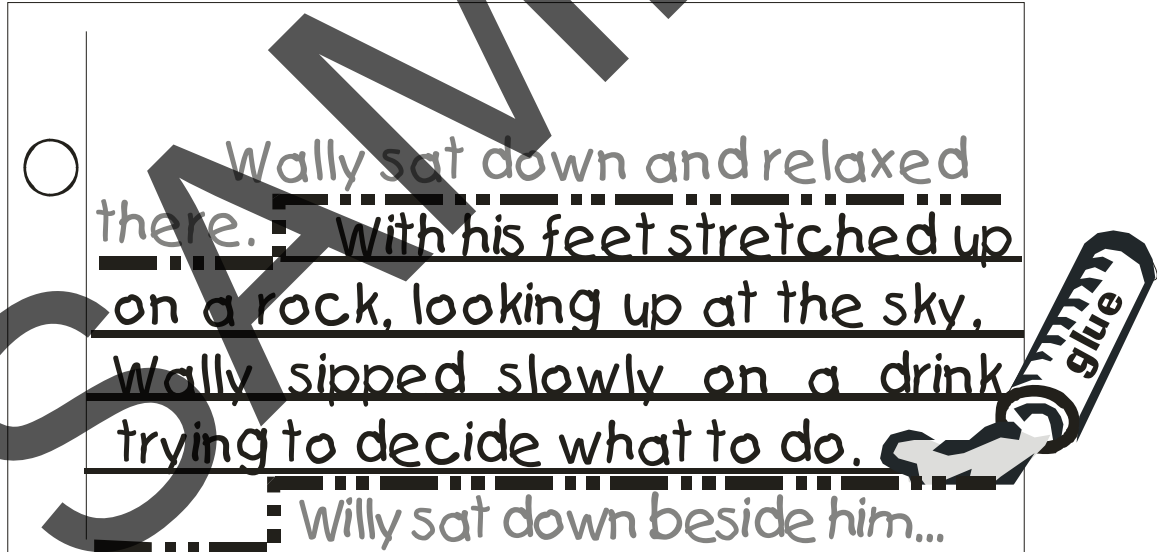

Students do not mind adding information but they hate rewriting the whole paper. This is an easy way to 'fix' their deficit areas. They also learn where to add information. It is not that they do not want to add more details; they just do not know 'where' they have left gaps in their writing.

- Students circle the information that will be in the second event/scene: the second post-it's information and feeling. Students take the post-it off and place it below their Introductory Paragraph on their writing paper. Using the details on the post-it, they rewrite the second event.

Feeling: excited

in clover joining the flock
Not to mention
unsuspecting tasty tidbit morsel
one lick of lamb resist
brush of lawn blade etc.

blinked.....suddenly gasped.....big eyes
better to see ewes with.....staring
big ears.....gulped.....lousy-looking coats
too cheep for peep sheep.....3 bags full
shrugged.....humidity.....damp weather
can't do a thing with it.....grinned
.....etc.....
naughty naked bid baa-aad wolves

Feeling: embarrassed

thought they had trouble with pigs
headed for the hills.....close shave
wait for hair to grow.....long time
very bad haircuts

Feeling: proud

eats were included.....on the lam
pull wool over eyes
fleece the flock.....bag of tricks
long-john woolies.....mascara
twittered.....dainty prance...etc.

Feeling: mischievous

out of breath.....lay low from law
"wanted" wolves.....dilemma
affirmative.....slurped
licked their lips.....brain ditto

Problem: Wolves want to trick and eat the sheep.

Intro: 2 wolves are running away from pigs
Who: Willy and Wally Wolf
When: daytime
Where: field

**Story Reading Narrative
Graphic Organizer**

Bad Boys
by Margie Palatini

- Students rewrite this paragraph in their own words. Students need to include D.A.D. in each body part: **D**escription, **A**ction, and **D**ialogue. Describe something, or someone in the area, using an assortment of attributes. Writers specify actions occurring. Remind them to include some dialogue in their writing. Remind students to infer how the main characters feel in their writing.
- Remind students that as a writer their creativity, imagination, and own backgrounds, could add interesting aspects to the story. This does NOT have to be an EXACT retelling. This retelling was designed to help your writers gain a sense of story and act as a guide for their own creations.
- As students complete their work, move around the room marking at least one area per student for cutting and pasting. I do not highlight more than one area per day to keep writers from getting disappointed with too many corrections.
- Students share their paragraphs.

Student Example #3

(template in Activity Sheets for the Week)

"No one will recognize us if we dress up as sheep and mix with the flock," chortled Willy pulling on his woolsuit.

"We might even get a delicious meal out of this adventure," snickered Wally.

The two villains put on make-up, dresses, high-heeled shoes and danced daintily towards the group of female sheep like two wolves in sheep's clothing.

"Now don't do anything until I give the signal," whispered Wally wiggling back and forth towards his dinner.

Yes, they were bad. Bad. really, really bad – but sort of cute, too.

Days #6:

1. Students reread the second event they wrote the previous day. Revise and edit their work before continuing and correcting the 'Cut & Paste' area.
2. Model cutting and pasting. Remind students that this activity replaces rewriting the whole event.
3. Students circle the information that will be in the third event/scene: the third post-it's information and feeling. Students take the post-it off and place it below their paragraph on their writing paper. Using the details on the post-it, they rewrite the third event.

Feeling: excited

in clover.....joining the flock
Not to mention
unsuspecting tasty tidbit.....morsel
one lick of lamb.....resist
brunch of lawn.....blade.....etc.

Feeling: proud

Feeling: mischievous

blinked.....suddenly gasped.....big eyes
better to see ewes with.....staring
big ears.....gulped.....lousy-looking coats
too cheep for peep sheep...3 bags full
shrugged.....humidity.....damp weather
can't do a thing with it.....grinned
.....etc.....
naughty naked bid baa-aad wolves

Feeling: embarrassed

thought they had trouble with pigs
headed for the hills.....close shave
wait for hair to grow.....long time
very bad haircuts

Feeling: excited

Feeling: proud

Feeling: mischievous

Feeling: embarrassed

Problem: Wolves want to trick and eat the sheep.

Intro: 2 wolves are running away from pigs
Who: Willy and Wally Wolf
When: daytime
Where: field

**Story Reading Narrative
Graphic Organizer**

Bad Boys
by Margie Palatini

4. Students rewrite this paragraph in their own words. Students need to include D.A.D. in each body part: **D**escription, **A**ction, and **D**ialogue. Describe something, or someone in the area, using an assortment of attributes. Writers specify actions that are occurring. Remind them to limit their writing to some exchanges of dialogue. Remind students to infer how the main characters feel in their writing.
5. Remind students that as a writer their creativity, imagination, and own backgrounds, could add interesting aspects to the story. This does NOT have to be an EXACT retelling. This retelling was designed to help your writers gain a sense of story and act as a guide for their own creations.
6. As students complete their work, move around the room marking at least one area per student for cutting and pasting. I do not highlight more than one area per day to keep writers from getting disappointed with too many corrections.
7. Students share their paragraphs.

Student Example #4

(template after Activity Sheets for the Week)

The two bad wolves decided to hide out from the law in the flock. The thought of mutton stew made the plan even more inviting.

Willy and Wally pretended to be enjoying tea and grass to trick the sheep into coming even closer.

"How do you do? I'm Betty and this is Trudie and Eve. Are you new around here?"

"Why yes," Willy answered sweetly, "I'm Willimina and this is Wallanda."

"We're sheep from Little Bo Peep's flock," added Wally. "We got lost coming home from school."

"Oh, too bad," signed Meryl. "Well, you have to be careful because there are two big bad wolves out there, my dears."

Beginning to get hungry thinking of mutton stew, Wally hurried the sheep to jump over the fence and head on.

Betty didn't want to jump. "You don't look like Bo's sheep. There's something weird about you," she said backing away from the fence.

Days #7:

1. Students reread the third event they wrote the previous day. Revise and edit their work before continuing and correcting the ‘Cut & Paste’ area.
2. Model cutting and pasting. Remind students that this activity replaces rewriting the whole event.
3. Students circle the information that will be in the fourth event/climax: the fourth post-it’s information and feeling. Students take the post-it off and place it below their paragraph on their writing paper. Using the details on the post-it, they rewrite the climax.

Feeling: excited

in cloverjoining the flock
Not to mention
unsuspecting tasty tidbitmorsel
one lick of lambresist
brunch of lawnblade.....etc.

eats were included.....on the lam
pull wool over eyes
fleece the flock.....bag of tricks
long-john wooliesmascara
twittered.....dainty prance.....etc.

Feeling: proud

out of breath.....lay low from law
"wanted" wolvesdilemma
affirmative.....slurped
licked their lipsbrain ditto

Feeling: mischievous

Feeling: embarrassed

blinked.....suddenly gasped.....big eyes
better to see ewes with.....staring
big ears.....gulped.....lousy-looking
too cheep for peep sheep.....
shrugged.....humidity.....damp w
can't do a thing with it.....grinned
.....etc.....
naughty naked bid baa-aad wolves

Feeling: embarrassed

thought they had trouble with pigs
headed for the hills.....close shave
wait for hair to grow.....long time
very bad haircuts

Problem: Wolves want to trick and eat the sheep.

Intro: 2 wolves are running away from pigs
Who: wily and Wally Wolf
When: daytime
Where: field

**Story Reading Narrative
Graphic Organizer**

Bad Boys
by Margie Palatini

4. Students rewrite this paragraph in their own words. Students need to include D.A.D. in each body part: **D**escription, **A**ction, and **D**ialogue. Describe something, or someone in the area, using an assortment of attributes. Writers specify actions occurring. Remind them to include dialogue and infer how the main characters feel in their writing.
5. Remind students that as a writer their creativity, imagination, and own backgrounds, could add interesting aspects to the story. This does NOT have to be an EXACT retelling. This retelling was designed to help your writers gain a sense of story and act as a guide for their own creations.

6. As students complete their work, move around the room marking at least one area per student for cutting and pasting. I do not highlight more than one area per day to keep writers from getting disappointed with too many corrections.
7. Students share their paragraphs.

Student Example #5

(template after Activity Sheets for the Week)

Suddenly Trudie cried, "Why Wallanda, what big eyes you have!"

"All the better to see you with," responded Wally.

"Why Willimina, what big ears you have!" bleated Meryl stepping closer to get a good look.

"All the better to hear you with," answered Willy.

"Wow! What cheap coats you have," said Betty.

"Oh, it's the humidity. The damp weather messes up our wool," blurted Wally.

"Come here and I'll help you," Betty gestured Wally and Willy to get in line.

Wally and Willy rush over to get in line with ideas of mutton for lunch.

BZZZZZZ.....BZZZZZZ.....BZZZZZZZ

"What's that noise, bees?" Wally and Willy began looking around...

Suddenly the sheep grabbed the two bad wolves, threw them on the ground, and shaved them BALD!

Embarrassed, naked, and hungry, the two bad wolves raced off into cornfields.

Days #8:

1. Students reread the climax they wrote the previous day.
2. Allow students to partner up and share their writing. This process helps students learn to revise their work and their 'Cut & Paste' areas.
3. Students might even change partners to help them with the editing phase of the writing. Writers often miss their punctuation and spelling mistakes because they see the words that they intended to write and miss the errors. Partner assistance improves the writing. All great authors have editors who correct and guide their corrections.

- Students circle the information that will be in the conclusion: the fifth post-it's information. Students take the post-it off and place it below their paragraph on their writing paper. Using the details on the post-it, they rewrite the conclusion. Remind writers that the conclusion often returns to some information in the introduction. The conclusion is short does not include any new information that must be elaborated. Authors like Robert Munsch often use the conclusion to create the beginning of a sequel to the story. I do not recommend getting into these types of stories at this point of instruction. Inexperienced writers tend to latch on to that type of conclusion when they do not know how they want to conclude their story. Once they have used this type of conclusion, it is difficult to motivate them into trying other types of conclusions as this method of concluding is easy.

Feeling: embarrassed

blinked...suddenly gasped...big eyes better to see ewes with...staring big ears...gulped...lousy-looking coats too cheep for peep sheep...3 bags full shrugged...humidity...damp weather can't do a thing with it...grinned...etc...naughty naked bid baa-aad wolves

Feeling: proud

eats were included...on the lam pull wool over eyes fleece the flock...bag of tricks long-john woolies...mascara twittered...dainty prance...etc.

Feeling: mischievous

out of breath...lay low from law "wanted" wolves...dilemma affirmative...stumped licked their lips...brain ditto

Problem: Wolves want to trick and eat the sheep.

Intro: 2 wolves are running away from pigs
Who: Willy and Wally Wolf
When: daytime
Where: field

Story Reading Narrative Graphic Organizer

Bad Boys
by Margie Palatini

- Students rewrite this paragraph in their own words. Remind students that as a writer their creativity, imagination, and own backgrounds, could add interesting information to the story.
- As students complete their work, move around the room marking at least one area per student for cutting and pasting. I do not highlight more than one area per day to keep writers from getting disappointed with too many corrections.

7. Students share their writing.

Student Example #6

(template after Activity Sheets for the Week)

The two bad wolves thought that the pigs were bad news? This shave was a bit too close for them.

The Big Bad Wolves raced off to wait for their hair to grow back - which took a VERY LONG TIME!

Days #9 - 10:

1. Distribute piece of 11" x 17" white paper and a half-of-a-pack of Post-It notes to each student.
2. Students place their paper horizontally on their desks.
3. Demonstrate drawing the narrative graphic organizer on the paper. Students draw the organizer on their own page (1), (2), (3).

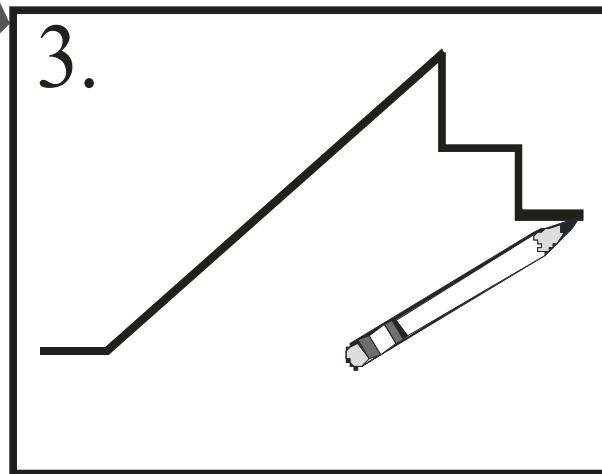
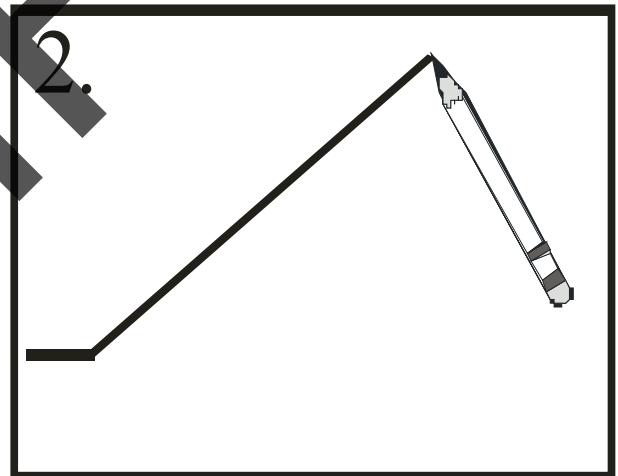
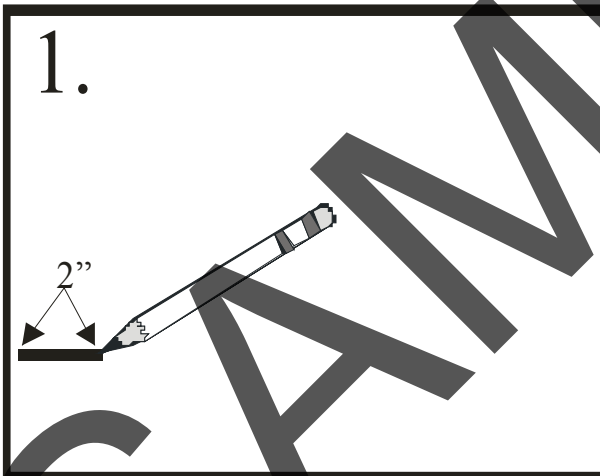

4. Model labeling the parts of the graphic organizer. The writers may want to use the complete words or the abbreviations on their planner. Below the line, students can write *Intro* for Introduction, *Who* for the characters, *When* for the time frame, *Where* for the setting. The Problem/Plot line should be written above the line and this line should extend enough to fit a sentence. The most exciting part is the *Climax* and this word (or abbreviation) is written at the peak of the mountain. The excitement then begins to decline as the solution to the problem occurs. The word or abbreviation for Solution should be written below the first step down. The story tapers to a close at the ending. The word or abbreviation for *Ending* is written on the second step down on the graphic organizer. Direct students to add a star or asterisk in front of the word ‘end’. In many stories, the writer returns to the characters or setting that were together in the beginning of the story. This type of ending draws the reader to a sense of completion. The writers are now ready to begin listening to the story.

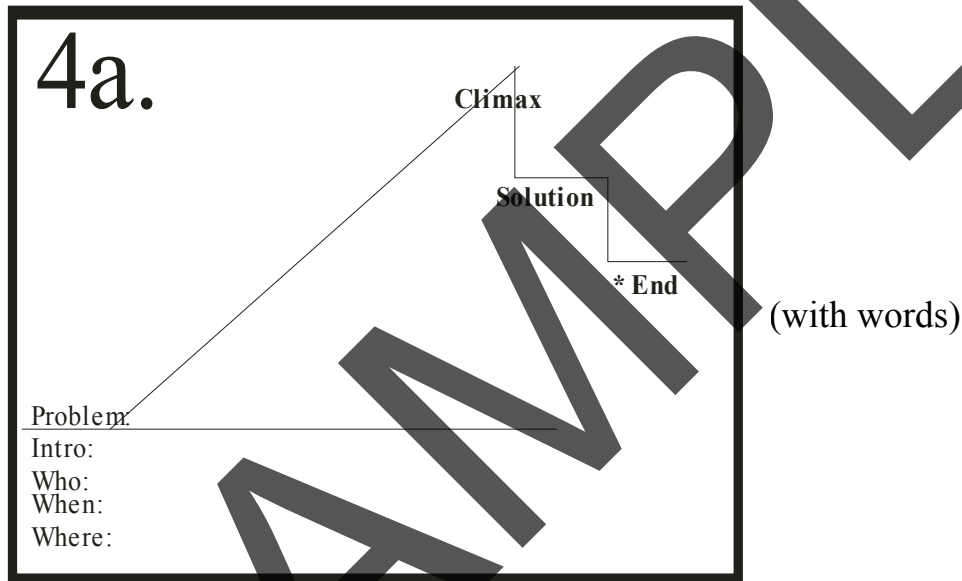

(with abbreviations)

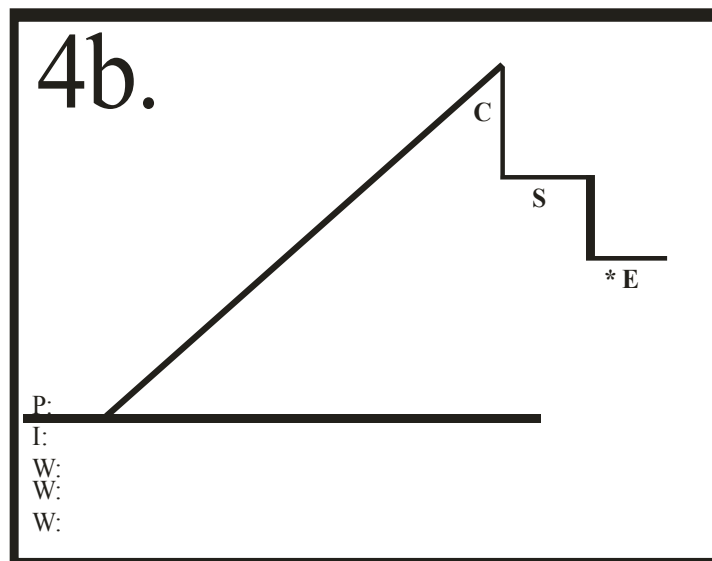

5. After drawing the Story Reading Narrative Graphic Organizer I, read the introduction of the story My Rotten Redheaded Brother by Patricia Polacco which ends with: “*The worst was that he was always telling me he could do just about everything better than I*”
6. Teacher assists students in completing the *Beginning Portion* of the graphic organizer.
 - a. Fill in Who, When (if evident), and Where.

Story Reading Narrative Graphic Organizer

My Rotten Red-Headed Older Brother
by Patricia Polacco

Climax

Solution

* End

Problem:

Intro: living with grandparents
 Who: grandmother, brother Richard, me
 When: when I was young
 Where: Union City, Michigan

SAMPLE

7. Students place a post-it on the first event-level of the graphic organizer. It belongs over or above and parallel to the problem line. If students write large or list so many ideas that they will not fit on this Post-It, suggest that another Post-It be situated right on top the first Post -It.
8. Read the story and stop every sentence or two to add details to the post-it notes. As the teacher reads each sentence slowly, students list details on the post-it from the next event ending with the words “... *‘Always have been and always will be’ he sneered.*” For example, after reading, stop and ask students to recall the words that were important to remember in this part of the story. Guide them towards the

words “*The worst was that he was always telling me he could do just about everything better than I*” to assist students in the retelling of the story. As the story is read, students will become more adept at pointing out the author’s details. When students point out a particular detail, the teacher should write it on the board for students to copy. It is important that they not become concerned with the spelling of the words and forget the details that they wanted to add to the story.

Story Reading Narrative Graphic Organizer

My Rotten Red-Headed Older Brother
by Patricia Polacco

climax

Solution

* End

couldn't stand.....everything better
pick blueberriesset a record
wasn't even challenged..... 10 years
run faster ...climb higherthrow farther
sit longerget dirtiestburp loudest

Problem: _____

Intro: living with grandparents
Who: grandmother, brother Richard, me
When: when I was young
Where: Union City, Michigan

9. After filling in the post-it with details, ask the students how the main character felt at this point of the story. The response might be “angry”, “annoyed”, “mad”. They write the word that suits the main character, as they see it. Showing students how authors infer ideas is an important part of the writing process. Ask the students, “Which words from the text let you know that he was scared?” Responses will vary from “*You make me sick!?*” to “*He had no equal, certainly not me*” he sneered.

couldn't stand.....everything better
pick blueberriesset a record
wasn't even challenged..... 10 years
run faster ...climb higherthrow farther
sit longerget dirtiestburp loudest

Feeling: annoyed

10. Students place a post-it on the second event-level of the graphic organizer. As the teacher reads each sentence slowly, students list details on the post-it from the next event (one page about looking at the night sky with Bubbie) ending with the words “*Richard gave me one of his extra-rotten, weasel-eyed, greeny-toothed grins.*” It’s important to stop after each sentence and elicit key words or details from the students until they get the idea. Details are specific words that the author uses to create a picture in the reader’s mind. Ask the students to write the complete expression that the author used. Keying in on phrases and clauses helps students raise the level of their own writing rather than just adding good adjectives and adverbs. (e.g.: “...had to be something” or “like a fresh breeze”)

Story Reading Narrative Graphic Organizer

My Rotten Red-Headed Older Brother
by Patricia Polacco

Problem:

Intro: living with grandparents
Who: grandmother, brother Richard, me
When: when I was young
Where: Union City, Michigan

climax

Solution

* End

had to be something...he couldn't inspired thought..... comforted me like a fresh breeze..... summer day rhubarb bush...sourest stuff....raw puckers...hissed looking smug, etc.

couldn't stand.....everything better pick blueberries.....set a record wasn't even challenged.....10 years run faster...climb higher....throw farther sit longer.....get dirtiest.....burp loudest

Feeling: annoyed

- a. After eliciting the feeling for this event, students share the details that they heard in the passage. As students read their details, other writers add new details to their post-its. Students might even count and compare the number of details in each event. They are very proud of the number of details that they recognize in each event. Discuss the repetition of dialogue and characters throughout the story. Focus on the interaction between Bubbie and her granddaughter.

had to be something...he couldn't inspired thought.... comforted me like a fresh breeze.....summer day rhubarb bush...sourest stuff....raw puckers..hissed looking smug...etc.

Feeling: angry

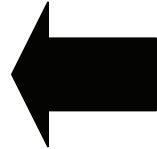

11. The reader now has an inkling of what the main problem in the story might be. Students should ask themselves: *What does the main character(s) want to accomplish in the story?* (What is the story about?) In this case, the main characters want to trick the sheep and eat them. Direct students to write the problem on the line that exemplifies this response.



Problem: Tricia wants to do something better than Richie.

Intro: living with grandparents
 Who: grandmother, brother Richard, me
 When: when I was young
 Where: Union City, Michigan

12. Students place a post-it on the third event level of the graphic organizer. Students list details independently on the post-it as the teacher reads this next event ending with the words, *"...My wish was to do something-anything-better than my brother. I'd show him!"* If the students need more assistance, feel free to model writing the details on the overhead or board after each sentence.

edge of my bed.....falling star streak across the sky..... spit twice between her fingers.... chest a loud slap...wish.... dark sky star shoot across the night.....etc.

had to be something...he couldn't inspired thought.... comforted me like a fresh breeze.....summer day rhubarb bush...sourest stuff....raw puckers..hissed looking smug...etc.

couldn't stand.....everything better pick blueberries.....set a record wasn't even challenged..... 10 years run faster...climb higher...throw farther sit longer.....get dirtiest.....burp loudest

Problem: Tricia wants to do something better than Richie.

Intro: living with grandparents
 Who: grandmother, brother Richard, me
 When: when I was young
 Where: Union City, Michigan

climax

Solution

* End

Feeling: angry

Feeling: annoyed

Story Reading Narrative Graphic Organizer

My Rotten Red-Headed Older Brother
 by Patricia Polacco

13. Discuss and label the feeling for this event.

➔ Feeling: hopeful

edge of my bed.....falling star
streak across the sky.....
spit twice between her fingers.....
chest a loud slap...wish.... dark sky
star shoot across the night.....etc.

14. Review the details on the post-it. Students turn and share with a partner. Writers add new details as other students are sharing. Discuss the hidden meaning behind the author’s word choice like...”slapped my chest,” “It was done,” and “I’d show him.”
15. Teacher calls on students to share their details. Remind students that great writers listen and learn from each other. After listening to one or two students share their details, ask if anyone else has a detail that has not been previously stated. As the students share their ideas, the teacher adds the details to the overhead.
16. Students place a post-it over the climax and solution because the two are so closely related that it’s difficult to know where one begins and the other ends.

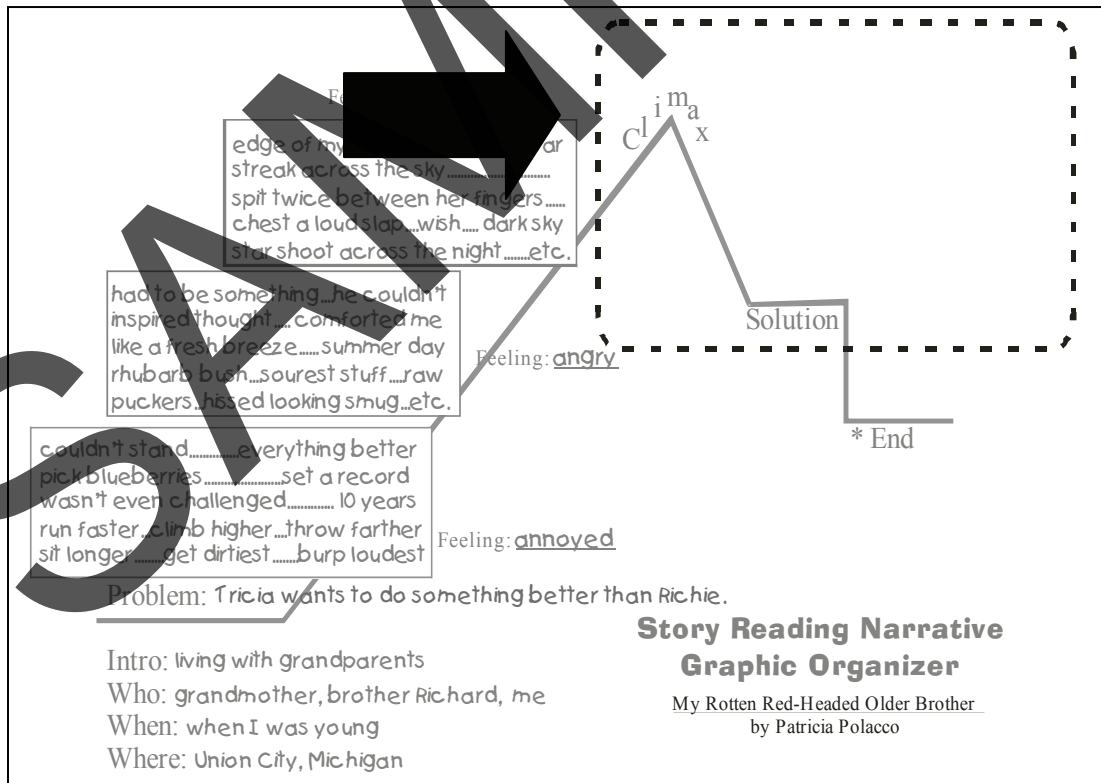

17. Students list details on the post-it as the teacher reads the climax and solution ending with the words, “...‘What’s a big brother for, anyway?’ he said, blushing.”

Feeling

edge of my bed
streak across the sky
spit twice between her fingers
chest a loud slap
wish
dark sky
star shoot across the night
etc.

had to be something...he couldn't
inspired thought...comforted me
like a fresh breeze...summer day
rhubarb bush...sourdest stuff...raw
puckers...hissed looking smug...etc.

couldn't stand...everything better
pick blueberries...set a record
wasn't even challenged...10 years
run faster...climb higher...throw farther
sit longer...get dirtiest...burp loudest

Feeling: **angry**

Feeling: **annoyed**

Problem: Tricia wants to do something better than Richie.

Intro: living with grandparents
Who: grandmother, brother Richard, me
When: when I was young
Where: Union City, Michigan

wagons and trucks.....Four Corners
traveling carnival...hot dogs...tease
sit up and take notice.....star wish
merry-go-round.....50 turns.....proud
fell off platform.....fell.....announced
biggest grin.....Dr. Lee.....stitches
etc.....
relationship changed.....blushing

* End

**Story Reading Narrative
Graphic Organizer**
My Rotten Red-Headed Older Brother
by Patricia Polacco

18. After discussing and sharing details, the teacher guides students through sharing the solution. The key that the solution has been reached (a negative one in this case) is that the reader no longer feels that Tricia going to attempt to outdo her brother. She is resigned to their situation and the story is over. I have the students circle the solution (the words: **relationship changed**- since that is what happened to Tricia and her brother) and star key words that the climax revolves around: **merry-go-round**. This will help them later see that these are the types of words that they'll place on their own narrative graphic organizers when they plan their own stories.

wagons and trucks.....Four Corners
traveling carnival...hot dogs...tease
sit up and take notice.....star wish
*** merry-go-round.....50 turns.....proud
fell off platform.....fell.....announced
biggest grin.....Dr. Lee.....stitches
etc.....
relationship changed.....blushing

My Rotten Red-Headed Older Brother
by Patricia Polacco

19. Students write a ‘feeling’ for the main character for the climax and solution.

Feeling: hopeful

edge of my bed.....falling star
streak across the sky.....
spit twice between her fingers.....
chest a loud slap.....wish..... dark sky
star shoot across the night.....etc.

had to be something...he couldn't
inspired thought..... comforted me
like a fresh breeze..... summer day
rhubarb bush.....sourest stuff.....raw
puckers...hissed looking smug...etc.

Feeling: angry

couldn't stand.....everything better
pick blueberries.....set a record
wasn't even challenged..... 10 years
run faster...climb higher...throw farther
sit longer.....get dirtiest.....burp loudest

Feeling: annoyed

Problem: Tricia wants to do something better than Richie.

Intro: living with grandparents
Who: grandmother, brother Richard, me
When: when I was young
Where: Union City, Michigan

wagons and trucks.....Four Corners
traveling carnival.....hot dogs...teased
sit up and take notice.....star wish
merry-go-round.....50 turns.....proud
fell off platform.....fell.....announced
biggest grin.....Dr. Lee.....stitches
.....etc.....
relationship changed.....blushing

Feeling: surprised

* End

**Story Reading Narrative
Graphic Organizer**

My Rotten Red-Headed Older Brother
by Patricia Polacco

20. Students place a post-it over the *End* portion of the graphic organizer.

Feeling: hopeful

edge of my bed.....falling star
streak across the sky.....
spit twice between her fingers.....
chest a loud slap.....wish..... dark sky
star shoot across the night.....etc.

had to be something...he couldn't
inspired thought..... comforted me
like a fresh breeze..... summer day
rhubarb bush.....sourest stuff.....raw
puckers...hissed looking smug...etc.

Feeling: angry

couldn't stand.....everything better
pick blueberries.....set a record
wasn't even challenged..... 10 years
run faster...climb higher...throw farther
sit longer.....get dirtiest.....burp loudest

Feeling: annoyed

Problem: Tricia wants to do something better than Richie.

Intro: living with grandparents
Who: grandmother, brother Richard, me
When: when I was young
Where: Union City, Michigan

wagons and trucks.....Four Corners
traveling carnival.....hot dogs...teased
sit up and take notice.....star wish
merry-go-round.....50 turns.....proud
fell off platform.....fell.....announced
biggest grin.....Dr. Lee.....stitches
.....etc.....
relationship changed.....blushing

Feeling: surprised

* End

**Story Reading Narrative
Graphic Organizer**

My Rotten Red-Headed Older Brother
by Patricia Polacco

21. Teacher guides the students through listing details on the post-it as the story is read to the end of the book.

Feeling: hopeful

edge of my bed.....falling star streak across the sky..... spit twice between her fingers..... chest a loud slap...wish.... dark sky star shoot across the nightetc.

wagons and trucks.....Four Corners traveling carnival....hot dogs...teased sit up and take notice.....star wish merry-go-round.....50 turnsproud fell off platform.....fell.....announced biggest grinDr. Lee.....stitchesetc..... relationship changed.....blushing

Feeling: surprised

out in yard.....family's custom sleep outside.....wishes are funny squeezed both of our hands..... hold onto grass.....kissed.....etc.

Feeling: angry

had to be something...he couldn't inspired thought comforted me like a fresh breeze..... summer day rhubarb bush...sourest stuff...raw puckers...hissed looking smug...etc.

Feeling: annoyed

couldn't stand.....everything better pick blueberries.....set a record wasn't even challenged..... 10 years run faster...climb higher...throw farther sit longerget dirtiest.....burp loudest

Problem: Tricia wants to do something better than Richie.

Intro: living with grandparents
Who: grandmother, brother Richard, me
When: when I was young
Where: Union City, Michigan

Story Reading Narrative Graphic Organizer
My Rotten Red-Headed Older Brother
by Patricia Polacco

22. Students enjoy counting up the number of details on all of their post-its. They are accomplished writers when they can identify the types of details that enliven a piece of writing. They are very proud at the end of this activity.
23. Ask the students to notice setting at the beginning of the book and again at the end. Point out that this is similar to a prompt: the reader ends up back where he started – Tricia and Richard are back with their grandmother. The asterisk is used to remind the reader to refer back to the beginning of the story in some way to create a sense of closure for the reader.



Keep this week's *My Rotten Red-Headed Older Brother's* graphic organizer for Week 7's writing lessons.

Sentence Work for the Week



Name: _____

Date: _____

Sentence Work for Week 5

1. Show me...

a broken robot
(Do not use the underlined word in your 'show-me' sentence.)

2. Said, said, said...

Little Timmy _____, "Boo! Hoo! I can't find my way home."

3. Begin a sentence about: a park with the word...

Before...

4. Be more specific...

The book was in the store.

Name: _____

Date: _____

Sentence Work for Week 5

1. Show me...

a silly chicken
(Do not use the underlined word in your 'show-me' sentence.)

2. Said, said, said...

John _____, "I'm so scared of the dark!"

3. Begin a sentence about: motorbike with the word...

Before...

4. Be more specific...

The animal slept in my room.

Name: _____

Date: _____

Sentence Work for Week 5

1. Show me...

A slow turtle
(Do not use the underlined word in your 'show-me' sentence.)

2. Said, said, said...

Joan _____, "Yow! I hit my finger with the hammer."

3. Begin a sentence about: movie with the word...

Before...

4. Be more specific...

The bug sat on a flower.

Name: _____

Date: _____

Sentence Work for Week 5

1. Show me...

an old hamster

(Do not use the underlined word in your 'show-me' sentence.)

2. Said, said, said...

Bobby _____, "Please give me my ball back!"

3. Begin a sentence about: giraffe with the word...

Before...

4. Be more specific...

The television show was on last night.

Name: _____

Date: _____

Sentence Work for Week 6

1. Show me...

loud music
(Do not use the underlined word in your 'show-me' sentence.)

2. Said, said, said...

Mikey _____, "I won \$100!"

3. Begin a sentence about: slippery slide with the word...

On...

4. Be more specific...

The building is in the city.

Name: _____

Date: _____

Sentence Work for Week 6

1. Show me...

an old movie
(Do not use the underlined word in your 'show-me' sentence.)

2. Said, said, said...

Jason _____, "My friend Joey moved away last month and I miss him."

3. Begin a sentence about: grocery store with the word...

On...

4. Be more specific...

The city in not on this continent.

Name: _____

Date: _____

Sentence Work for Week 6

1. Show me...

a nosy neighbor
(Do not use the underlined word in your 'show-me' sentence.)

2. Said, said, said...

Becky _____, "I can help you with your problem."

3. Begin a sentence about: bus ride with the word...

On...

4. Be more specific...

The newspaper was on the doorstep.

Name: _____

Date: _____

Sentence Work for Week 6

1. Show me...

a friendly lady
(Do not use the underlined word in your 'show-me' sentence.)

2. Said, said, said...

Steve _____, "I-I-I can't look down from this bridge."

3. Begin a sentence about: riding with the word...

On...

4. Be more specific...

My friend ate at a restaurant.

Activity Sheets for the Week



Student Sample Introductions – for Overhead*(For rewrite of Bad Boys by Margie Palatini)***#1**

The day was hot but the pigs were hotter! Hopping hot and mad at the two big bad boys, Willy and Wally Wolf escaped across the field.

#2

Willy and Wally Wolf barely escaped the angry pigs as they took off across Potter's field that blazing hot Friday afternoon.

#3

Who would have thought that two wolves could get in so much trouble – But Willy and Wally Wolf could get in trouble any time of day. It was a Saturday afternoon in May, “Help! Help! Help!” yelled Willy and Wally Wolf as they ran through the cornfield only inches in front of a mad mob of pigs.

#4

Willy and Wally Wolf raced across the cornfield with the pigs close behind. This was going to be a long day.

Student Example #2 – for Overhead*(For rewrite of Bad Boys by Margie Palatini)*

“Wally, I think that we did it! For a while there, I thought that we were goners!” chuckled Willy removing his old dress.

“Not me! I knew that we were far too clever for them,” retorted Wally wiping the corn leaves from his pants. “We were just too bad for them!”

Out of breath, the two wolves collapsed on the side of the road and decided to lay low from the law for a while.

“How are we going to hide out, Wally?” questioned Willy relaxing against the fence post and slowly sipping on his drink.

Suddenly, Wally and Willy both jumped up to a delicious sound in the distance, “Baa.”

“Did you hear that?” whispered Wally as Willy pushed aside the cornstalks to a herd of sheep heading towards them.

“Are you thinking what I’m thinking?” said Wally as he licked his lips.

“I sure am!” said Willy.

Student Example #3 – for Overhead*(For rewrite of Bad Boys by Margie Palatini)*

“No one will recognize us if we dress up as sheep and mix with the flock,” chortled Willy pulling on his wool suit.

“We might even get a delicious meal out of this adventure,” snickered Wally.

The two villains put on make-up, dresses, high-heeled shoes and danced daintily towards the group of female sheep like two wolves in sheep’s clothing.

“Now don’t do anything until I give the signal,” whispered Wally wiggling back and forth towards his dinner.

Yes, they were bad. Bad. really, really bad – but sort of cute, too.

Student Example #4 – for Overhead*(For rewrite of Bad Boys by Margie Palatini)*

The two bad wolves decided to hide out from the law in the flock. The thought of mutton stew made the plan even more inviting.

Willy and Wally pretended to be enjoying tea and grass to trick the sheep into coming even closer.

“How do you do? I’m Betty and this is Trudie and Eve. Are you new around here?”

“Why yes,” Willy answered sweetly, “I’m Willimina and this is Wallanda.”

“We’re sheep from Little Bo Peep’s flock,” added Wally. “We got lost coming home from school.”

“Oh, too bad,” signed Meryl. “Well, you have to be careful because there are two big bad wolves out there, my dears.”

Beginning to get hungry thinking of mutton stew, Wally hurried the sheep to jump over the fence and head on.

Betty didn’t want to jump. “You don’t look like Bo’s sheep. There’s something weird about you,” she said backing away from the fence.

Student Example #5 – for Overhead*(For rewrite of Bad Boys by Margie Palatini)*

Suddenly Trudie cried, “Why Wallanda, what big eyes you have!”

“All the better to see you with,” responded Wally.

“Why Willimina, what big ears you have!” bleated Meryl stepping closer to get a good look.

“All the better to hear you with,” answered Willy.

“Wow! What cheap coats you have,” said Betty.

“Oh, it’s the humidity. The damp weather messes up our wool,” blurted Wally.

“Come here and I’ll help you,” Betty gestured Wally and Willy to get in line.

Wally and Willy rush over to get in line with ideas of mutton for lunch.

BZZZZZZZ.....BZZZZZZZ.....BZZZZZZZZ

“What’s that noise, bees?” Wally and Willy began looking around...

Suddenly the sheep grabbed the two bad wolves, threw them on the ground, and shaved them BALD!

Embarrassed, naked, and hungry, the two bad wolves raced off into cornfields.

Student Example #6 – for Overhead
(For rewrite of Bad Boys by Margie Palatini)

The two bad wolves thought that the pigs were bad news? This shave was a bit too close for them.

The Two Big Bad Wolves raced off to wait for their hair to grow back - which took a VERY LONG TIME!