

Name: _____ Date: _____

Daily Prompt Check: Week 1

Math is important.

Before you begin writing, think about why math is an important subject.

Now explain to the reader of your paper why math is an important subject.

Everyone has experienced a very special day.

Before you begin writing, think about a day that you thought was very special.

Now write a story about what happened on that special day.

Everyone has a favorite restaurant.

Before you begin writing, think about your favorite restaurant.

Now write to explain why you enjoy eating at this particular restaurant.

Many people watch television every day.

Think about all of the television shows that you enjoy watching.

Now explain to the reader of your paper what television shows you enjoy.

Taking care of your family is important.

Before you begin writing, think about why you should take care of your family.

Now write to explain why taking care of your family members is important.

SAMPLE

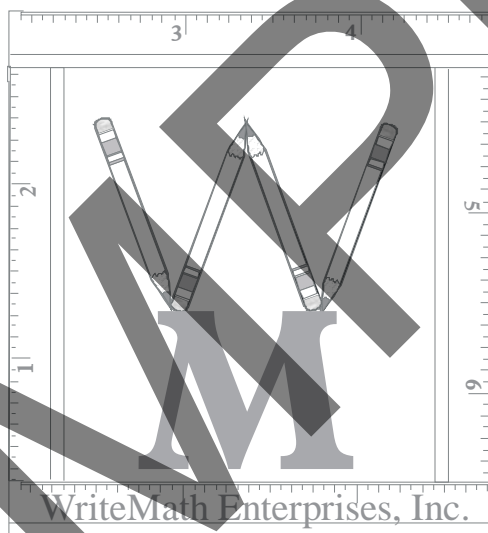

Name: _____

Date: _____

Two Types of Writing

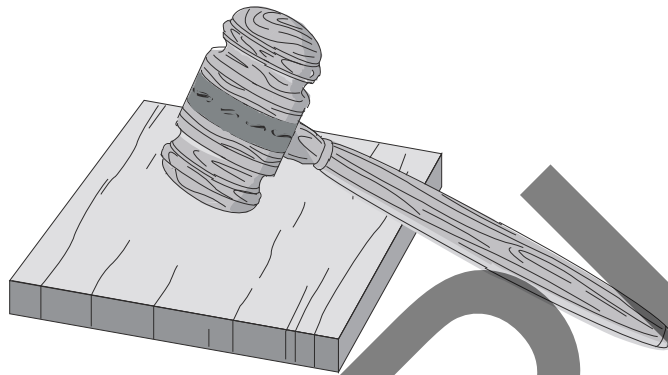

expository = explain



narrative = story

SAMPLE

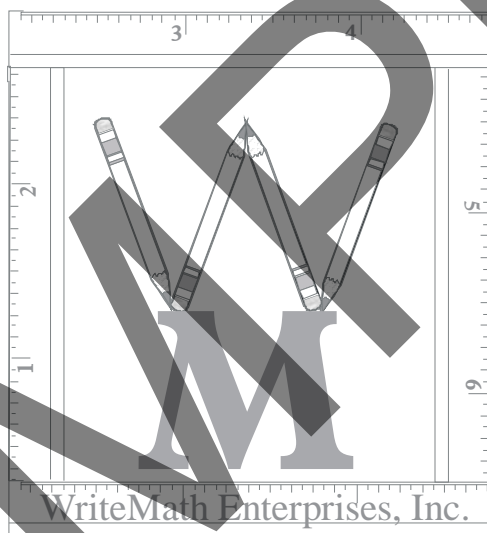

Name: _____ Date: _____

Expository Signal Words

- explain

- clarify

- inform

- **DEFINE**

- **INSTRUCT**

Name: _____ Date: _____

Narrative Signal Words

- **TELL ABOUT A TIME**

- **Write about an experience**

- **STORY**

explain

Name: _____ Date: _____

Vocabulary Words for the Week

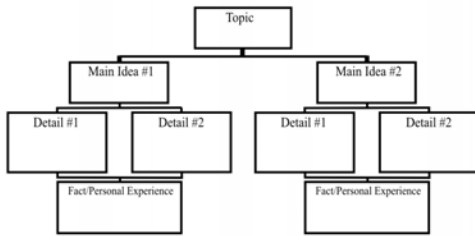

Expository Writing

explain

clarify

inform

define

instruct

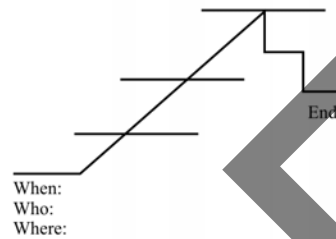

Narrative Writing

write

tell

story

~~explain~~

SAMPLE

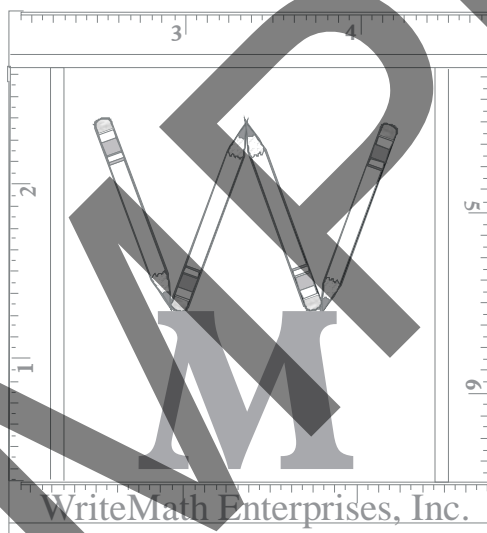

Name: _____

Date: _____

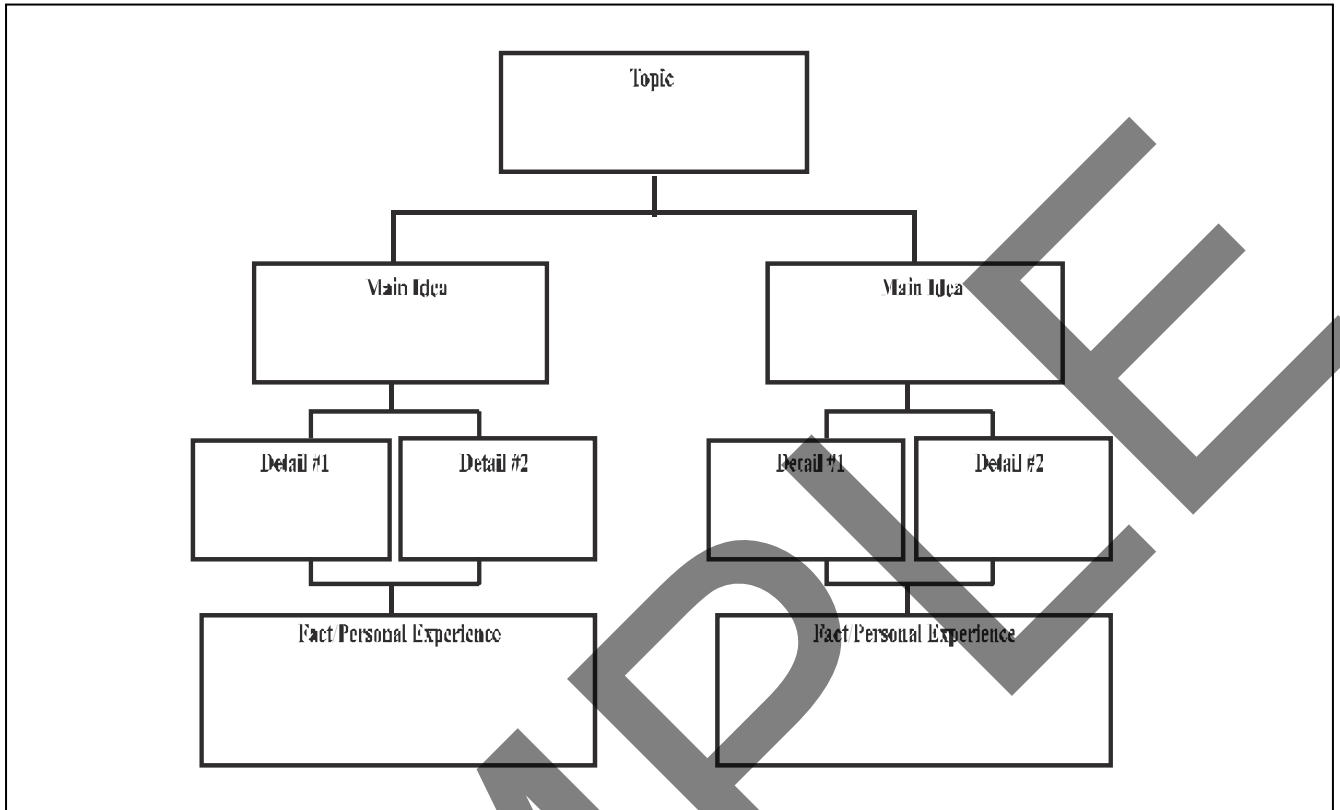

Narrative Graphic Organizer

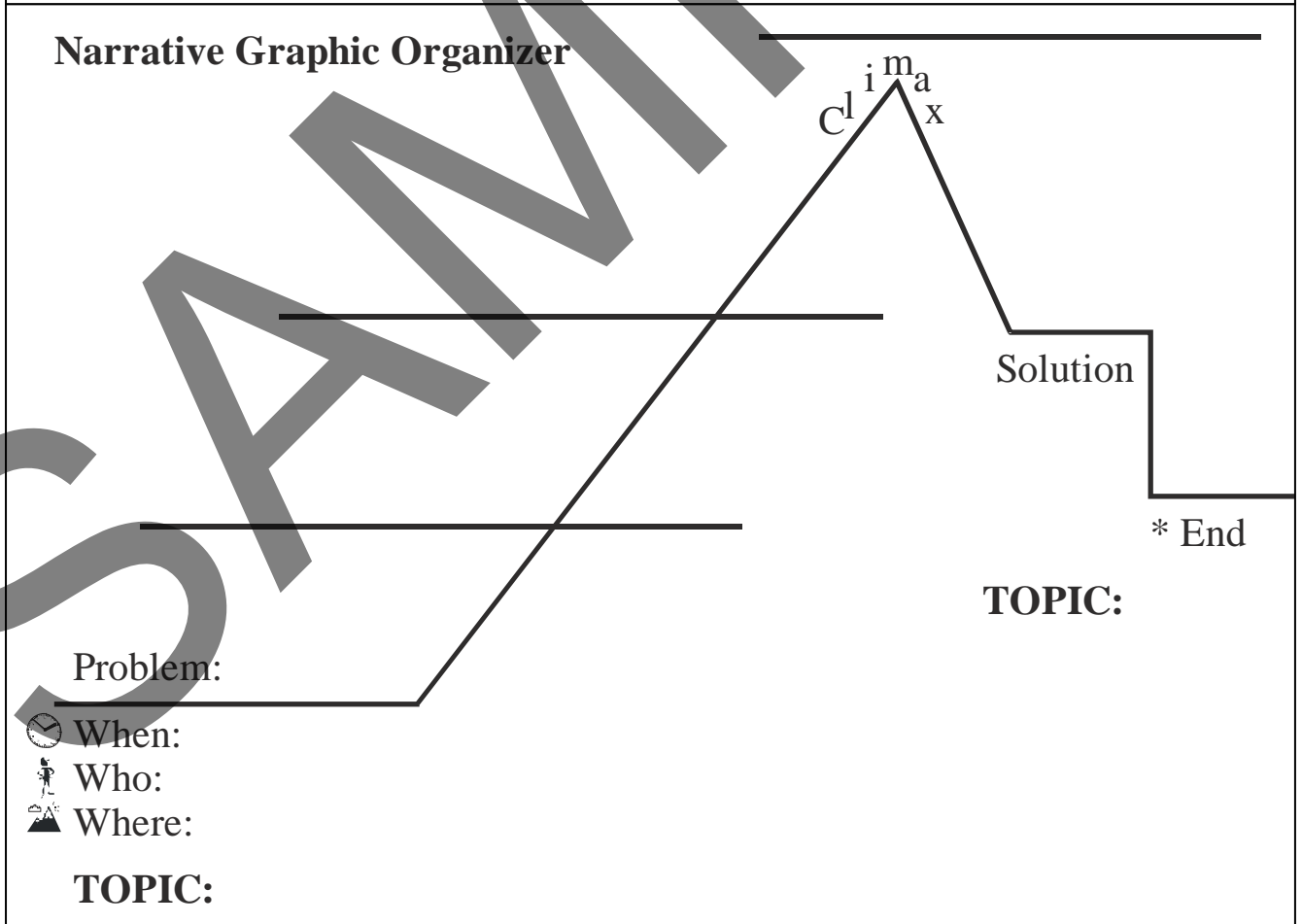

SAMPLE

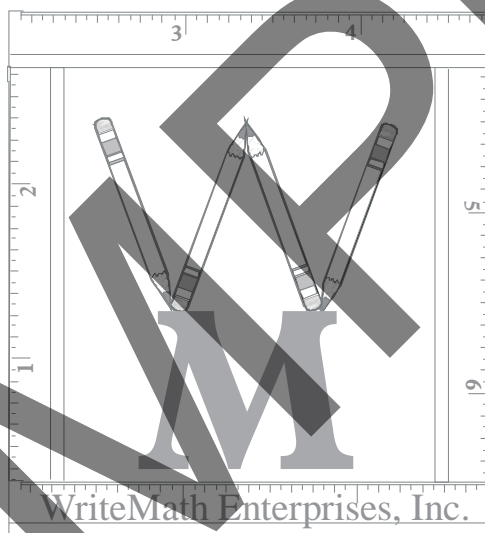

Name: _____ Date: _____

What is an **ESSAY**?



An essay is a short piece of writing about **one** topic.

Shape of an Essay

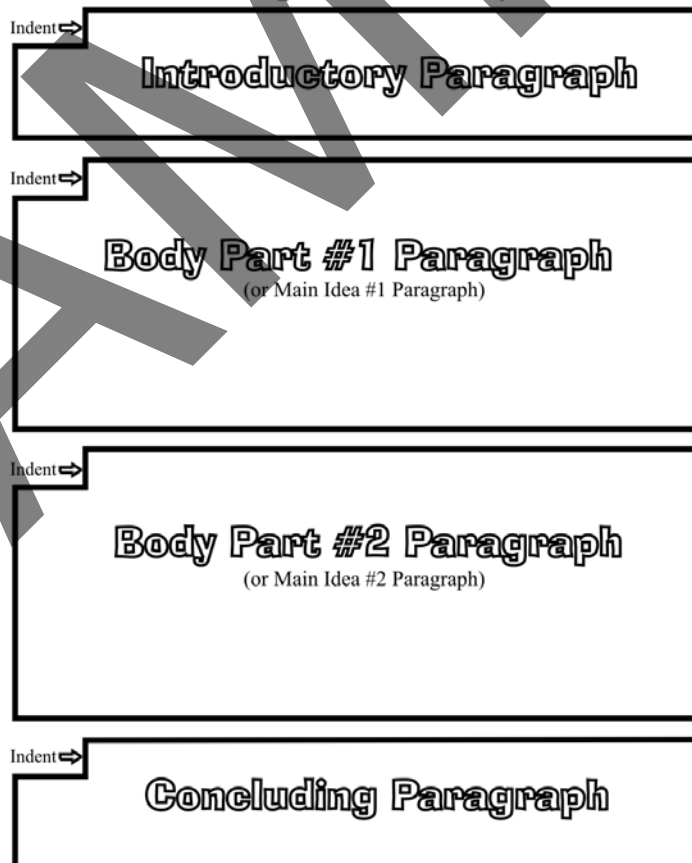

Name: _____ Date: _____

An essay contains paragraphs.

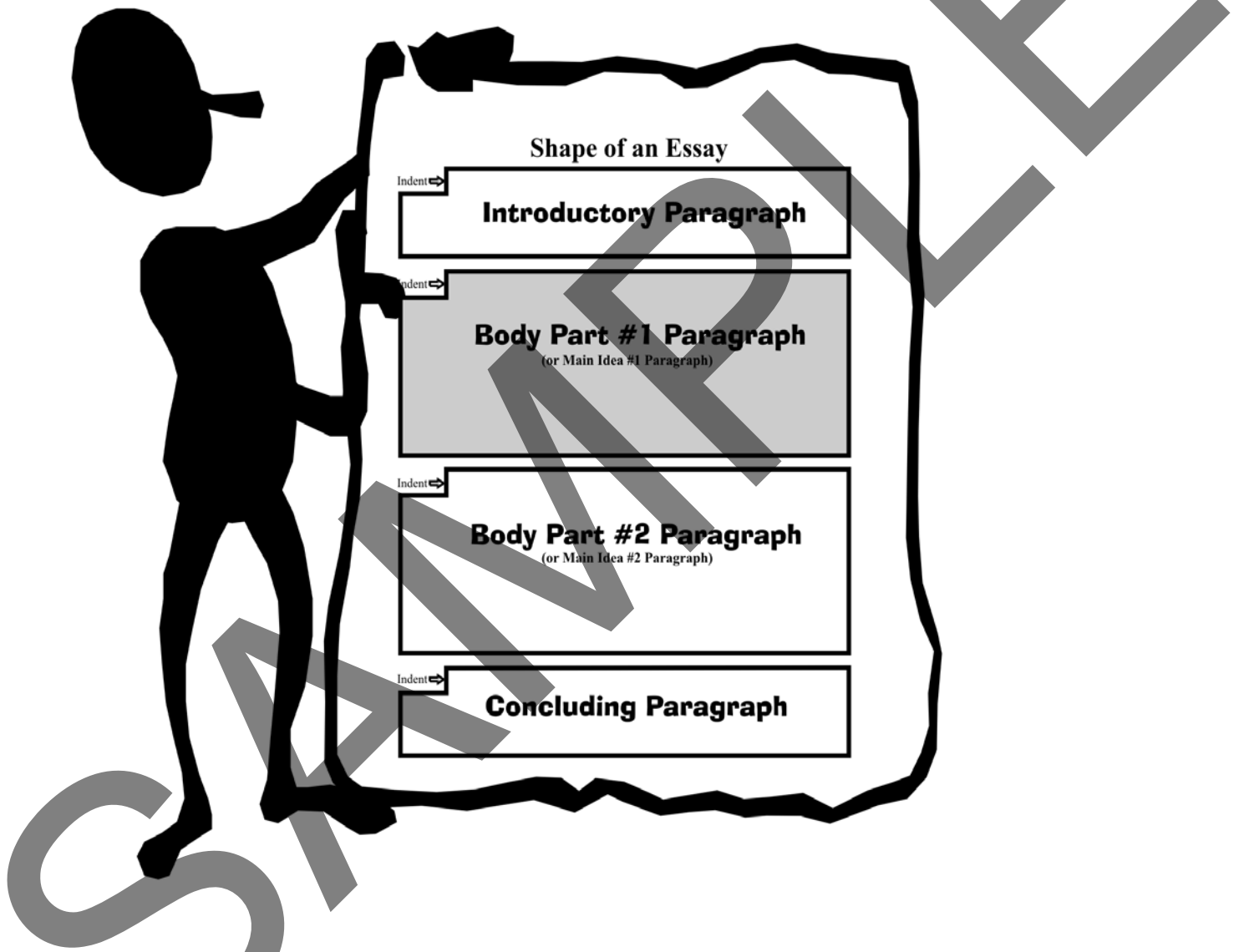

A **paragraph** is a portion of an author's writing based on one main idea or event.

Name: _____ Date: _____

Outline the Paragraph Activity



Snakes, Snakes, Snakes



The cry of "SNAKE" captivates children's attention everywhere. The noise, feel, and movement of a snake generates interest regarding these ground-slithering creatures.

There are over 2,500 species of snakes around the world. Most snakes live on land, but several types inhabit salt or fresh water. Land snakes live underground or in trees, or deep in rocky crevices. Snakes range in length from around 4 inches to 31 feet. The smallest snake known to man is the blind snake, while the largest snake found on earth is the python.

Many snakes are beneficial to man. They kill insects and rodents keep them from overwhelming our environment. Shoes, purses, boots, and other articles of clothing are made from snakeskin. Soups, dips, and Jerky strips are delicate food items that tantalize many American appetites.

Most species of snakes bite in self-defense or for eating purposes. While the bite of several specimens are harmless, the bite of some venomous snakes are deadly.

Snakes are cold-blooded creatures found mainly in warmer regions of the world, but are known to hibernate during the winters in colder areas of the world. Even though they enjoy warm weather, they are often inactive during extremely hot summers.

The body of a snake is long and usually slender. The shape of a snake's head varies from species to species. Many snakes have a pit between their eyes that enable them to detect warm-blooded animals from a great distance. Elastic ligaments, attaching the lower jaw to the head, allow the snake to spread its mouth wide enough to swallow animals whole. Its prey is often wider than the snake's head. The elasticity of the skin permits large animals to pass through the snake's digestive system with ease.

A snake always looks like it's staring at you because it does not have eyelids. The eye is protected from damage by a transparent protective membrane. Snakes have an acute sense of smell that enables them to detect prey from a great distance. Unlike humans, snakes do not have external ears. Their inner ear is well developed to hear only low-frequency sounds. They often detect predators and prey through sound vibrations created in the ground.

Forked tongues are a unique attribute of the snake species. The tongue is like a nose. The tongue carries all odors to an organ of smell in its mouth. Snakes continuously flick their tongue in and out of their mouths searching for a prey's scent. Snakes feed on a variety of living creatures such as frogs, insects, mice, rats snails, birds, other snakes, and eggs.

SAMPLE

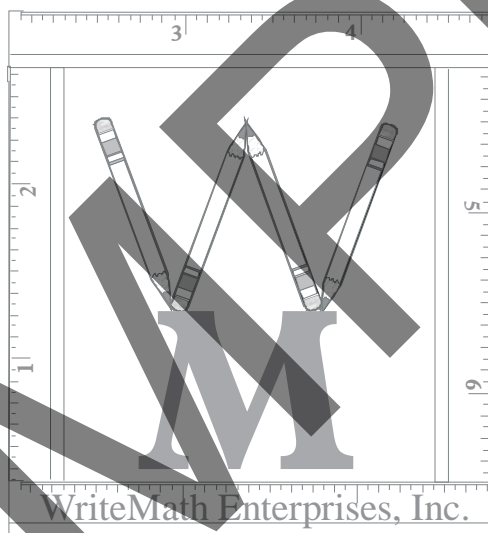

Name: _____ Date: _____

Directions: Color 'Essay' handout & place in writing folder.

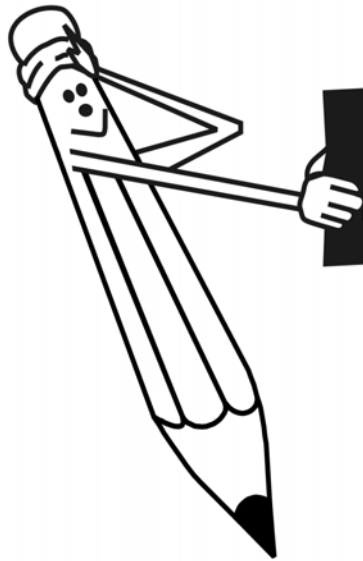

Essay

Introductory Paragraph

Body Part #1 Paragraph

Body Part #2 Paragraph

Concluding Paragraph

SAMPLE

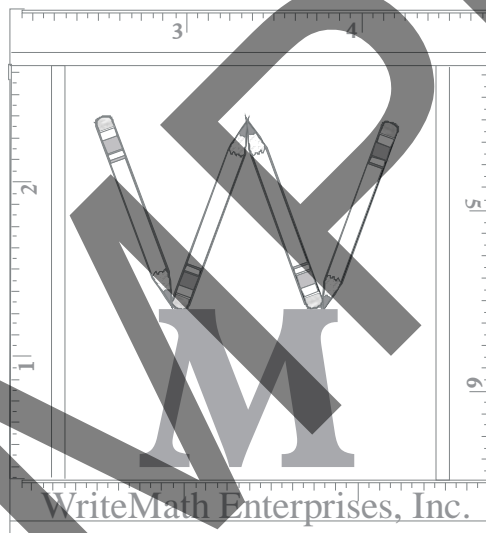

Name: _____ Date: _____

Shape of an Essay

Indent ⇨

Introductory Paragraph

Indent ⇨

Body Part #1
(or Main Idea #1 Paragraph)

Indent ⇨

Body Part #2
(or Main Idea #2 Paragraph)

Indent ⇨

Concluding Paragraph

SAMPLE

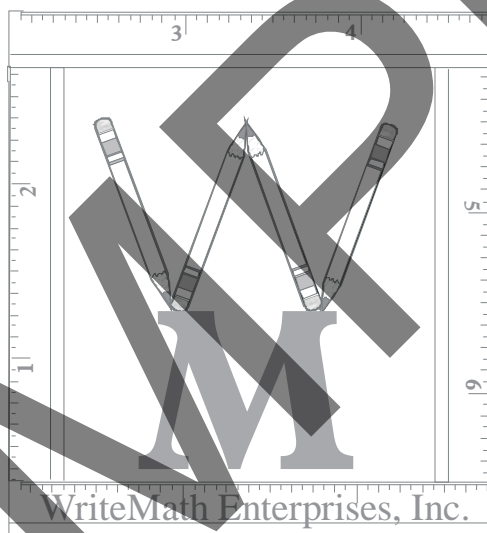

Name: _____ Date: _____

Essay Parts

Introductory Paragraph

Indent →

_____ and _____

Body Part #1 Paragraph

Indent →

Body Part #2 Paragraph

Indent →

Concluding Paragraph

Indent →

Name: _____ Date: _____

Essay Parts

Introductory Paragraph

Indent →

_____ and _____

Body Part #1 Paragraph

Indent →

Body Part #2 Paragraph

Indent →

Concluding Paragraph

Indent →

Name: _____ Date: _____

Essay Parts

Introductory Paragraph

Indent →

_____ and _____

Body Part #1 Paragraph

Indent →

Body Part #2 Paragraph

Indent →

Concluding Paragraph

Indent →

Name: _____ Date: _____

Essay Parts

Introductory Paragraph

Indent →

_____ and _____

Body Part #1 Paragraph

Indent →

Body Part #2 Paragraph

Indent →

Concluding Paragraph

Indent →

Name: _____ Date: _____

Essay Parts

Introductory Paragraph

Indent →

_____ and _____

Body Part #1 Paragraph

Indent →

Body Part #2 Paragraph

Indent →

Concluding Paragraph

Indent →

SAMPLE

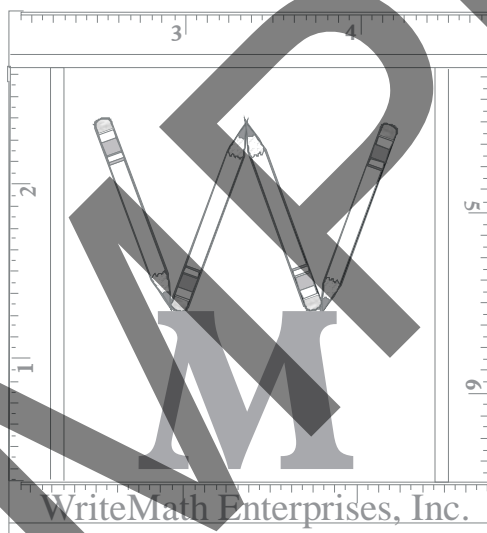

Journal Sample

After school yesterday, I played outside with my friends. We played soccer and my brother and I beat our cousins. It was fun. Then we went down to the creek to catch some frogs and crawdads. We each brought a bucket. I caught 2 frogs and Taylor caught 3 crawdads. Then we went back home for dinner.

SAMPLE

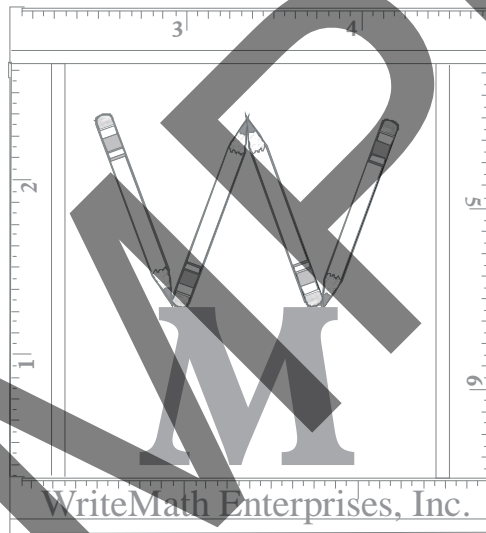

Sentence Information

- A sentence is a group of words that expresses a complete thought.
(Hint: A sentence must make sense.)

For example: Chrissy won the race.

- ♦ This is a sentence because it expresses a complete thought.
- ♦ The reader knows who is doing the action and what the action was.

For example: does the ribbon.

- ♦ This is a not sentence because it does not express a complete thought.
- ♦ The reader does not know the action..

- A sentence contains a **subject** and a **predicate**.

Subject

- A subject is the noun, or noun phrase, that does the action.

For example: Steven caught the football.

- ♦ *Steven* is doing the action.
- ♦ *Steven* is the subject.

- A subject is the noun, or noun phrase, that the predicate is about or that the predicate modifies.

For example: The football is in the backyard.

- ♦ The sentence is about *the football*.
- ♦ *The football* is the subject.

Predicate

- The predicate is the action part of the sentence.

For example: Amy dove into the water.

- ♦ *dove into the water* is the action part of the sentence.
- ♦ *dove into the water* is the predicate.

- The predicate tells about the subject.

For example: Melissa is a talented actress.

- ♦ *is a talented actress* is about the subject *Melissa*.
- ♦ *is a talented actress* is the predicate.

SAMPLE

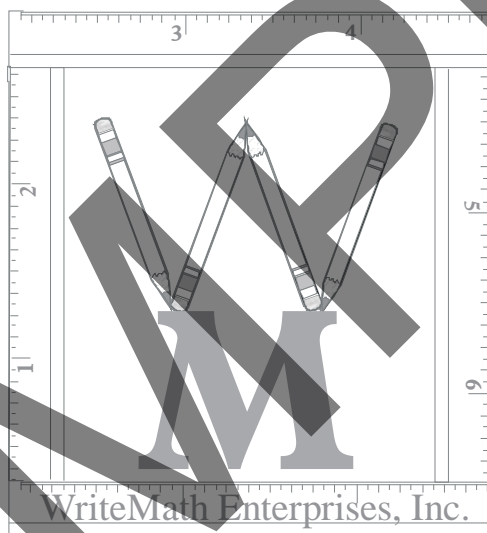

Name: _____ Date: _____

Directions:

- Draw a line between the subject and the predicate. (The little boy \ ran to the store.)
(S)
- Write an 'S' above the subject. (The little boy \ ran to the store.)
(S)
- Underline the predicate. (The little boy \ ran to the store.)

Day #1

1. Mrs. Robinson writes stories.
2. Mr. Green reads many types of books.
3. Michael Smith entered our classroom from the hall.
4. The first day of school went by quickly.

For Sentences #5 - 6
Topic: Science is important

5. Write a statement about the above topic.
 For example: Science is an extremely important school subject.
(Do not use this sentence. Write your own.)

- Check box if you have:
- capital at the beginning of the sentence
 - period at the end of the sentence

6. Write a question about the topic.
 For example: Why is science so important in today's world?
(Do not use this sentence. Write your own.)

- Check box if you have:
- capital at the beginning
 - question mark at the end

Name: _____ Date: _____

Directions:

- Draw a line between the subject and the predicate. (The little boy \ ran to the store.)
(S)
- Write an 'S' above the subject. (The little boy \ ran to the store.)
(S)
- Underline the predicate. (The little boy \ ran to the store.)

Day #2

1. The batter hit the ball over the fence.
2. The astonished fans cheered for Jose Juarez.
3. The Devil Ray’s baseball team practices in Tampa, Florida.
4. The refreshment stand was closed by 8:00 PM.

For Sentences #5 - 7
Topic: A special holiday

5. Write a statement about the above topic.

Check box if you have:

- capital at the beginning of the sentence
- period at the end of the sentence

6. Write a question about the topic.

Check box if you have:

- capital at the beginning
- question mark at the end

7. Write a quotation about the topic. For example: Mom cried, “Your birthday is such a special holiday.” *(Do not use this sentence. Write your own).*

Check box if you have:

- capital at the beginning
- period at the end
- quotation marks
- capital at the beginning of the quotation

Name: _____ Date: _____

Directions:

- Draw a line between the subject and the predicate. (The little boy \ ran to the store.)
(S)
- Write an 'S' above the subject. (The little boy \ ran to the store.)
(S)
- Underline the predicate. (The little boy \ ran to the store.)

Day #3

1. Davy Crockett was a famous American frontiersman.
2. He was born on August 17, 1786.
3. Davy Crockett helped frontier settlers during the early years of our country.
4. Davy Crockett defended the Alamo during the struggle for Texas independence.

For Sentences #5 - 8
Topic: Favorite Park

5. Write a statement about the above topic.

Check box if you have:

- capital at the beginning of the sentence
- period at the end of the sentence

6. Write a question about the topic.

Check box if you have:

- capital at the beginning
- question mark at the end

8. Write a quotation about the topic.

Check box if you have:

- capital at the beginning
- period at the end
- quotation marks
- capital at the beginning of the quotation

Name: _____ Date: _____

Directions:

- Draw a line between the subject and the predicate. (The little boy \ ran to the store.)
(S)
- Write an 'S' above the subject. (The little boy \ ran to the store.)
(S)
- Underline the predicate. (The little boy \ ran to the store.)

Day #4

1. Whaling ships hunted whales for their blubber.
2. The whaling ship, *Ann Alexander*, made oil out of whale blubber.
3. The crew of the *Ann Alexander* harpooned a whale on August 20, 1857.
4. The whale attacked and destroyed the vessel.

For Sentences #5 - 7
Topic: **TV Shows**

5. Write a statement about the above topic.

Check box if you have:

- capital at the beginning of the sentence
- period at the end of the sentence

6. Write a question about the topic.

Check box if you have:

- capital at the beginning
- question mark at the end

7. Write a quotation about the topic.

Check box if you have:

- capital at the beginning
- period at the end
- quotation marks
- capital at the beginning of the quotation

8. Write a sentence with a list of three items based on the topic. For example: Every Thursday night I watch the news on Channel 8, Crocodile Hunter, and Home Improvement.

Check box if you have:

- capital at the beginning
- period at the end
- at least two commas
- the word "and" before the last item in the list